

The genomes of recombinant inbred lines

Karl W Broman

Department of Biostatistics
Johns Hopkins University

<http://www.biostat.jhsph.edu/~kbroman>



C57BL/6



3

The intercross

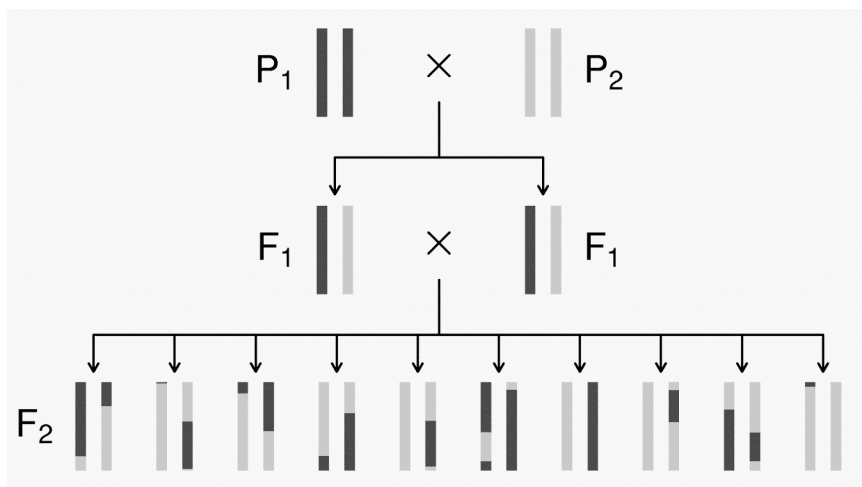

4

Recombinant inbred lines (by sibling mating)

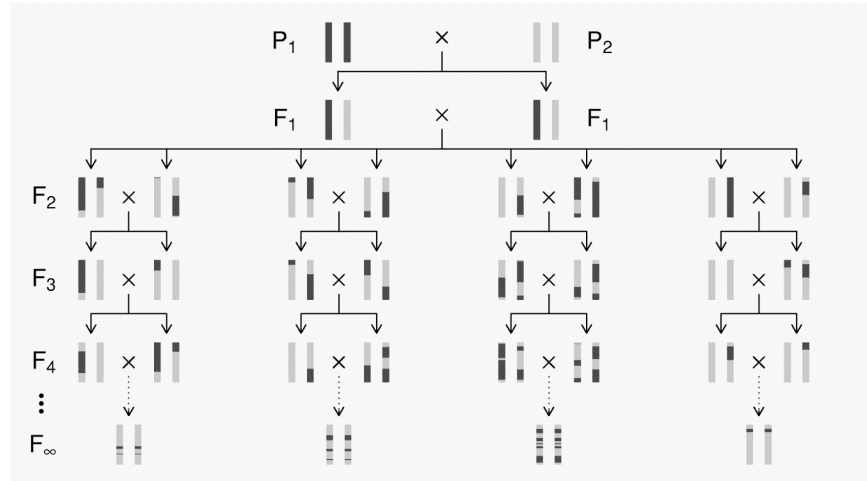

5

The RIX design

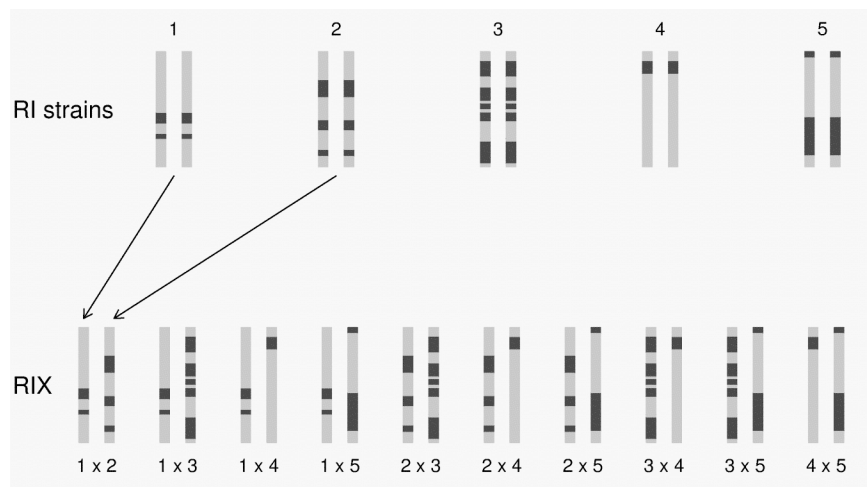

6

The Collaborative Cross

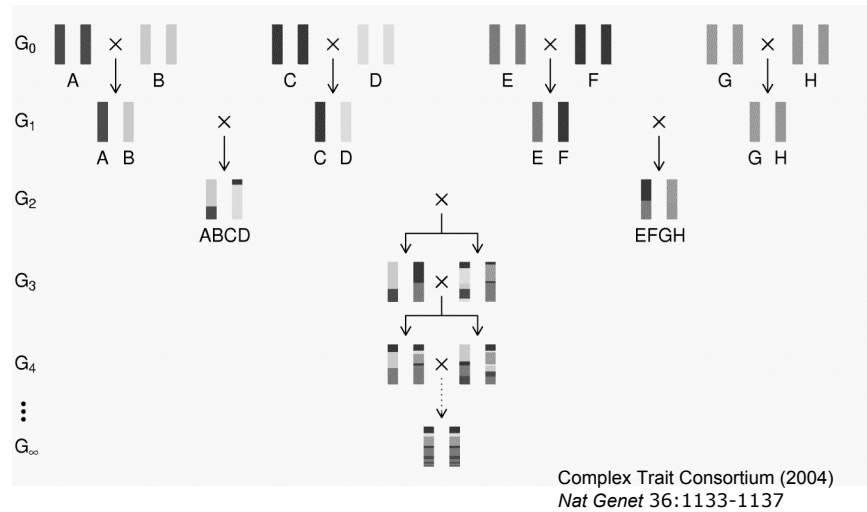

7

Genome of an 8-way RI

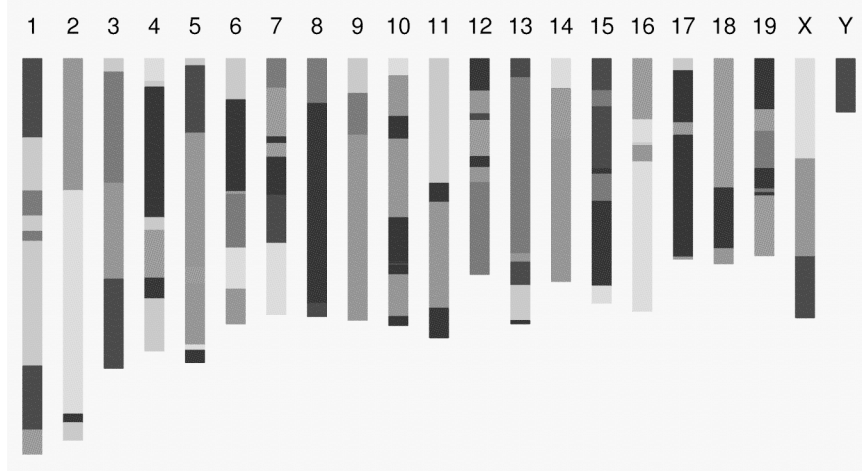

8

The goal

(for the rest of this talk)

- Characterize the breakpoint process along a chromosome in 8-way RILs.
 - Understand the two-point haplotype probabilities.
 - Study the clustering of the breakpoints, as a function of crossover interference in meiosis.

9

2 points in an RIL



- r = recombination fraction = probability of a recombination in the interval in a random meiotic product.
- R = analogous thing for the RIL = probability of different alleles at the two loci on a random RIL chromosome.

10

Haldane & Waddington 1931

INBREEDING AND LINKAGE*

J. B. S. HALDANE AND C. H. WADDINGTON
John Innes Horticultural Institution, London, England

Received August 9, 1930 Genetics 16:357-374

TABLE OF CONTENTS

	PAGE
Self-fertilization	358
Brother-sister mating. Sex-linked genes	360
Brother-sister mating. Autosomal genes	364
Parent and offspring mating. Sex-linked genes	367
Parent and offspring mating. Autosomal genes	368
Inbreeding with any initial population	370
Double crossing over	372
DISCUSSION	373
SUMMARY	374
LITERATURE CITED	374

When a heterozygous population is self-fertilized or inbred the ultimate result (apart from effects of mutation) is complete homozygosis. The final proportions of the various genotypes are usually independent of the system of inbreeding adopted, although, as JENNINGS (1916) and others have shown, the speed at which equilibrium is approached is greater in the case of self-fertilization than of brother-sister mating, and so on.

Recombinant inbred lines (by selfing)

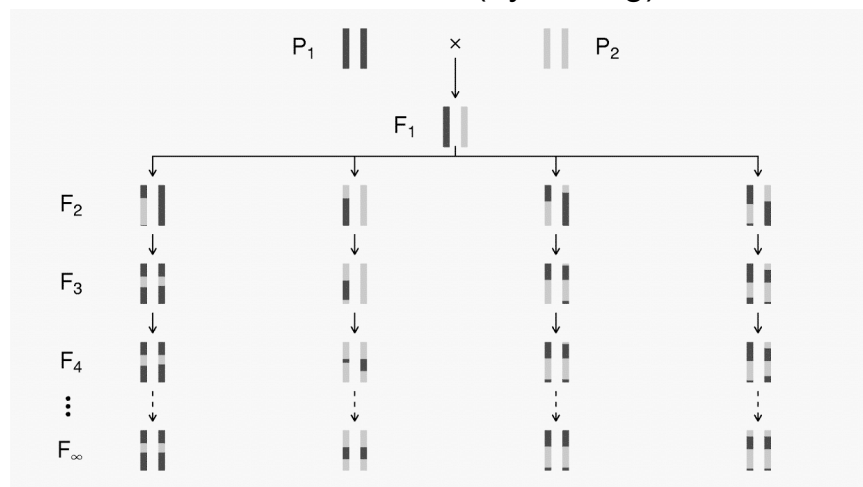

Markov chain

- Sequence of random variables $\{X_0, X_1, X_2, \dots\}$ satisfying
$$\Pr(X_{n+1} | X_0, X_1, \dots, X_n) = \Pr(X_{n+1} | X_n)$$
- Transition probabilities $P_{ij} = \Pr(X_{n+1}=j | X_n=i)$
- Here, X_n = "parental type" at generation n
- We are interested in absorption probabilities

$$\Pr(X_n \rightarrow j | X_0)$$

13

Absorption probabilities

Let $P_{ij} = \Pr(X_{n+1} = j | X_n = i)$ where X_n = state at generation n .

Consider the case of absorption into the state AA|AA.

Let h_i = probability, starting at i , eventually absorbed into AA|AA.

Then $h_{AA|AA} = 1$ and $h_{AB|AB} = 0$.

Condition on the first step: $h_i = \sum_k P_{ik} h_k$

For selfing, this gives a system of 3 linear equations.

14

Equations for selfing

C_n *AABB* and *aabb*.
 D_n *AAbb* and *aaBB*.
 E_n *AABb*, *AaBB*, *Aabb*, and *aaBb*.
 F_n *AB.ab*.
 G_n *Ab.aB*.

We assume $2C_n + 2D_n + 4E_n + F_n + G_n = 2$, so that $C_1 = D_1 = E_1 = G_1 = 0$, and $F_1 = 2$. Clearly $E_\infty = F_\infty = G_\infty = 0$, and D_∞ is the final proportion of crossover zygotes. Then considering the results of selfing each generation, we have:

$$\begin{cases}
 C_{n+1} = C_n + \frac{1}{2}E_n + \frac{1}{4}(1 - \beta - \delta + \beta\delta)F_n + \frac{1}{4}\beta\delta G_n \\
 D_{n+1} = D_n + \frac{1}{2}E_n + \frac{1}{4}\beta\delta F_n + \frac{1}{4}(1 - \beta - \delta + \beta\delta)G_n \\
 E_{n+1} = \frac{1}{2}E_n + \frac{1}{4}(\beta + \delta - 2\beta\delta)(F_n + G_n) \\
 F_{n+1} = \frac{1}{2}(1 - \beta - \delta + \beta\delta)F_n + \frac{1}{2}\beta\delta G_n \\
 G_{n+1} = \frac{1}{2}\beta\delta F_n + \frac{1}{2}(1 - \beta - \delta + \beta\delta)G_n
 \end{cases} \quad (1.1)$$

for C_{n+1} , D_{n+1} , and F_{n+1} , G_{n+1} ,

$$\left. \begin{matrix} d_n \\ \dots \end{matrix} \right\} \quad (1.2)$$

for all values of n .
 $- 2x)d_n$

$$= \frac{1 - 2x}{1 + 2x}$$

Put $y = D_\infty$ (the final proportion of crossover zygotes)

$$\therefore C_\infty + D_\infty = 1, C_\infty - D_\infty = c_\infty \therefore y = \frac{1}{2}(1 - c_\infty)$$

$$\Rightarrow \therefore y = \frac{2x}{1 + 2x}$$

$$(1.3)$$

15

Recombinant inbred lines (by sibling mating)

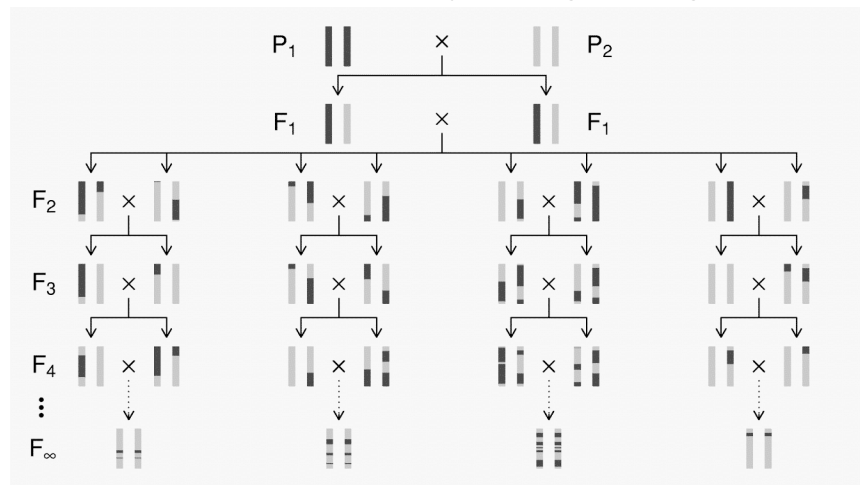

16

Equations for sib-mating

Typical mating	Number of types	Equation
$AABB \times AABB$	2	$C_{n+1} = C_n + H + \frac{1}{2}(\alpha^2 + \gamma^2)L + \frac{1}{4}(\beta^2 + \delta^2)N + \frac{1}{2}Q + \frac{1}{2}R + \frac{1}{2}(\alpha^2 + \gamma^2)U + \frac{1}{2}(\beta^2 + \delta^2)V + \frac{1}{2}\alpha\beta\gamma\delta W + \frac{1}{4}(\alpha^2\beta^2 + \beta^2\gamma^2)X + \frac{1}{4}\alpha^2\beta^2\delta^2 Y$
$AAbb \times AAbb$	2	$D_{n+1} = D + I + \frac{1}{2}(\alpha^2 + \gamma^2)M + \frac{1}{4}(\beta^2 + \delta^2)P + \frac{1}{2}Q + \frac{1}{2}S + \frac{1}{2}(\beta^2 + \delta^2)U + \frac{1}{2}(\alpha^2 + \gamma^2)V + \frac{1}{2}\alpha\beta\gamma\delta W + \frac{1}{4}(\alpha^2\beta^2 + \beta^2\gamma^2)X + \frac{1}{4}\alpha^2\gamma^2 Y$
$AABB \times aabb$	2	$E_{n+1} = \frac{1}{2}\alpha\beta\gamma\delta W + \frac{1}{4}(\alpha^2\beta^2 + \beta^2\gamma^2)X + \frac{1}{4}\alpha^2\beta^2\delta^2 Y$
$AAbb \times aaBB$	2	$F_{n+1} = \frac{1}{2}\alpha\beta\gamma\delta W + \frac{1}{4}(\alpha^2\beta^2 + \beta^2\gamma^2)X + \frac{1}{4}\alpha^2\gamma^2 Y$
$AABB \times AAbb$	8	$G_{n+1} = \frac{1}{2}H(\alpha\beta + \gamma\delta)(U+V) + \frac{1}{2}\alpha\beta\gamma\delta(W+2X+Y)$
$AAbb \times AABB$	8	$H_{n+1} = \frac{1}{2}I(\alpha\beta + \gamma\delta)(U+V) + \frac{1}{2}\alpha\beta\gamma\delta(W+2X+Y)$
$AAbb \times AAbb$	8	$I_{n+1} = \frac{1}{2}J(\alpha\beta + \gamma\delta)(U+V) + \frac{1}{2}\alpha\beta\gamma\delta(W+2X+Y)$
$AAbb \times AAbb$	8	$J_{n+1} = \frac{1}{2}K(\alpha\beta + \gamma\delta)(U+V) + \frac{1}{2}\alpha\beta\gamma\delta(W+2X+Y)$
$AAbb \times AAbb$	8	$K_{n+1} = \frac{1}{2}L(\alpha\beta + \gamma\delta)(U+V) + \frac{1}{2}\alpha\beta\gamma\delta(W+2X+Y)$
$AABB \times Ab.aB$	4	$L_{n+1} = \frac{1}{2}M(\alpha\beta + \gamma\delta)(U+V) + \frac{1}{2}\alpha\beta\gamma\delta(W+2X+Y)$
$AAbb \times Ab.aB$	4	$M_{n+1} = \frac{1}{2}N(\alpha\beta + \gamma\delta)(U+V) + \frac{1}{2}\alpha\beta\gamma\delta(W+2X+Y)$
$AABB \times Ab.aB$	4	$N_{n+1} = \frac{1}{2}R + \frac{1}{2}(\alpha\beta + \gamma\delta)(U+V) + \frac{1}{2}\alpha\beta\gamma\delta(W+2X+Y)$
$AAbb \times Ab.aB$	4	$P_{n+1} = \frac{1}{2}S + \frac{1}{2}(\alpha\beta + \gamma\delta)(U+V) + \frac{1}{2}\alpha\beta\gamma\delta(W+2X+Y)$
$AAbb \times AAbb$	4	$Q_{n+1} = 2G + \frac{1}{2}(H+I+J+K) + \frac{1}{2}(\alpha^2 + \gamma^2)(L+M) + \frac{1}{2}(\beta^2 + \delta^2)(N+P) + \frac{1}{2}Q + \frac{1}{2}(R+S+T) + \frac{1}{2}(\alpha^2 + \alpha\beta + \beta^2 + \gamma^2 + \gamma\delta + \delta^2)(U+V) + \frac{1}{2}\alpha\beta(\alpha\delta + \beta\gamma)(W+Y) + \frac{1}{2}(\alpha\gamma + \beta\delta)X$
$AAbb \times AAbb$	4	$R_{n+1} = \frac{1}{2}(\beta^2 + \delta^2)L + \frac{1}{2}(\alpha^2 + \gamma^2)N + \frac{1}{2}R + \frac{1}{2}(\beta^2 + \delta^2)U + \frac{1}{2}(\alpha^2 + \gamma^2)V + \frac{1}{2}\alpha\beta(\alpha\delta + \beta\gamma)(W+Y) + \frac{1}{2}(\alpha\gamma + \beta\delta)X$
$AAbb \times AAbb$	4	$S_{n+1} = \frac{1}{2}(\beta^2 + \delta^2)M + \frac{1}{2}(\alpha^2 + \gamma^2)P + \frac{1}{2}S + \frac{1}{2}(\alpha^2 + \gamma^2)U + \frac{1}{2}(\beta^2 + \delta^2)V + \frac{1}{2}\alpha\beta(\alpha\delta + \beta\gamma)(W+Y) + \frac{1}{2}(\alpha\gamma + \beta\delta)X$
$AAbb \times aaBb$	4	$T_{n+1} = \frac{1}{2}(\alpha\beta + \gamma\delta)(U+V) + \frac{1}{2}\alpha\beta\gamma\delta(W+Y) + \frac{1}{2}(\alpha\gamma + \beta\delta)X$
$AAbb \times Ab.ab$	8	$U_{n+1} = \frac{1}{2}J + \frac{1}{2}(\alpha\beta + \gamma\delta)(L+N) + \frac{1}{2}(S+T) + \frac{1}{2}(\alpha^2 + \gamma^2)U + \frac{1}{2}(\beta^2 + \delta^2)V + \frac{1}{2}\alpha\beta\gamma\delta W + \frac{1}{4}(\alpha\gamma + \beta\delta)(\alpha\delta + \beta\gamma)X + \frac{1}{4}\alpha\beta\delta(\beta\gamma + \alpha\delta)Y$
$AAbb \times Ab.ab$	8	$V_{n+1} = \frac{1}{2}K + \frac{1}{2}(\alpha\beta + \gamma\delta)(M+P) + \frac{1}{2}(R+T) + \frac{1}{2}(\beta^2 + \delta^2)U + \frac{1}{2}(\alpha^2 + \gamma^2)V + \frac{1}{2}\alpha\beta\delta(\beta\gamma + \alpha\delta)W + \frac{1}{4}(\alpha\gamma + \beta\delta)(\alpha\delta + \beta\gamma)X + \frac{1}{4}\alpha\beta\gamma(\beta\gamma + \alpha\delta)Y$
$Ab.ab \times Ab.ab$	1	$W_{n+1} = 2(E+J) + \frac{1}{2}(\alpha^2 + \gamma^2)L + \frac{1}{2}(\beta^2 + \delta^2)N + \frac{1}{2}(S+T) + \frac{1}{2}(\alpha^2 + \gamma^2)U + \frac{1}{2}(\beta^2 + \delta^2)V + \frac{1}{2}\alpha\beta\gamma\delta W + \frac{1}{4}(\alpha^2\beta^2 + \beta^2\gamma^2)X + \frac{1}{4}\alpha^2\beta^2\delta^2 Y$
$Ab.ab \times Ab.ab$	2	$X_{n+1} = \frac{1}{2}T + \frac{1}{2}(\alpha\beta + \gamma\delta)(U+V) + \frac{1}{2}\alpha\beta\gamma\delta(W+2X+Y)$
$Ab.ab \times Ab.ab$	1	$Y_{n+1} = 2(F+K) + \frac{1}{2}(\alpha^2 + \gamma^2)M + \frac{1}{2}(\beta^2 + \delta^2)P + \frac{1}{2}(R+T) + \frac{1}{2}(\beta^2 + \delta^2)U + \frac{1}{2}(\alpha^2 + \gamma^2)V + \frac{1}{2}\alpha\beta\gamma\delta W + \frac{1}{4}(\alpha^2\beta^2 + \beta^2\gamma^2)X + \frac{1}{4}\alpha^2\gamma^2 Y$

17

Result for sib-mating

Omitting some rather tedious algebra, the solution of these equations is:

$$\zeta = \frac{q}{2-3q}, \quad \theta = \frac{2q}{2-3q}, \quad \kappa = \frac{1}{2-3q},$$

$$\lambda = \frac{1-2q}{2-3q}, \quad \mu = \frac{1-2q}{2-3q}, \quad \nu = \frac{2q}{2-3q}$$

as may easily be verified.

$$\therefore c_{\infty} = c_n + 2e_n + \frac{1}{1+6x} [(1-2x)(d_n + 2f_n + 2j_n + \frac{1}{2}k_n) + 2g_n + 4x(h_n + i_n)] \quad (3.4)$$

and $y = \frac{1}{2}(1 - c_{\infty})$.

In the case considered, $d_0 = 1$, $\therefore c_{\infty} = \frac{1}{1+6x}$. Hence the proportion of crossover zygotes $y = \frac{4x}{1+6x}$ (3.5).

18

The "Collaborative Cross"

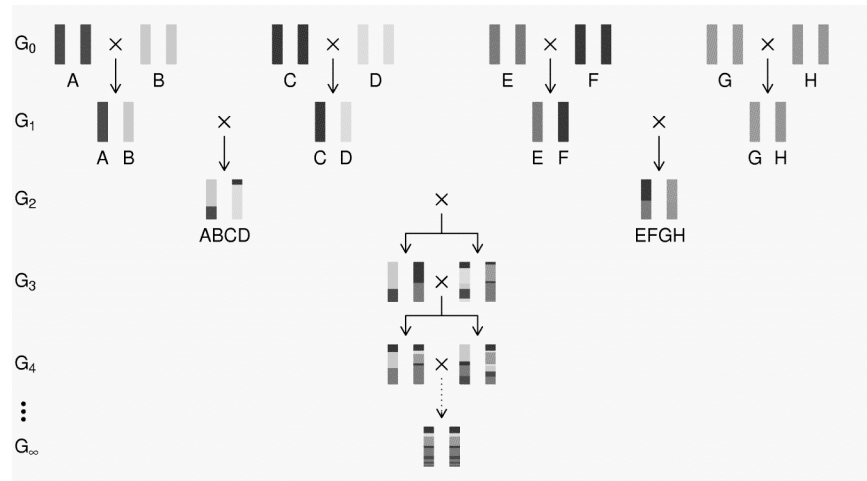

19

8-way RILs

Autosomes

$$\Pr(G_1 = i) = 1/8$$

$$\Pr(G_2 = j \mid G_1 = i) = r / (1+6r) \quad \text{for } i \neq j$$

$$\Pr(G_2 \neq G_1) = 7r / (1+6r)$$

X chromosome

$$\Pr(G_1=A) = \Pr(G_1=B) = \Pr(G_1=E) = \Pr(G_1=F) = 1/6$$

$$\Pr(G_1=C) = 1/3$$

$$\Pr(G_2=B \mid G_1=A) = r / (1+4r)$$

$$\Pr(G_2=C \mid G_1=A) = 2r / (1+4r)$$

$$\Pr(G_2=A \mid G_1=C) = r / (1+4r)$$

$$\Pr(G_2 \neq G_1) = (14/3) r / (1+4r)$$

20

The X chromosome

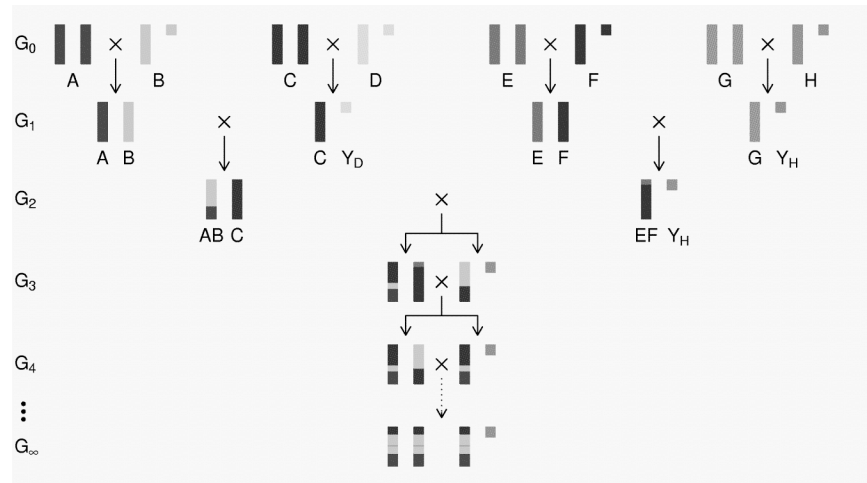

21

Computer simulations

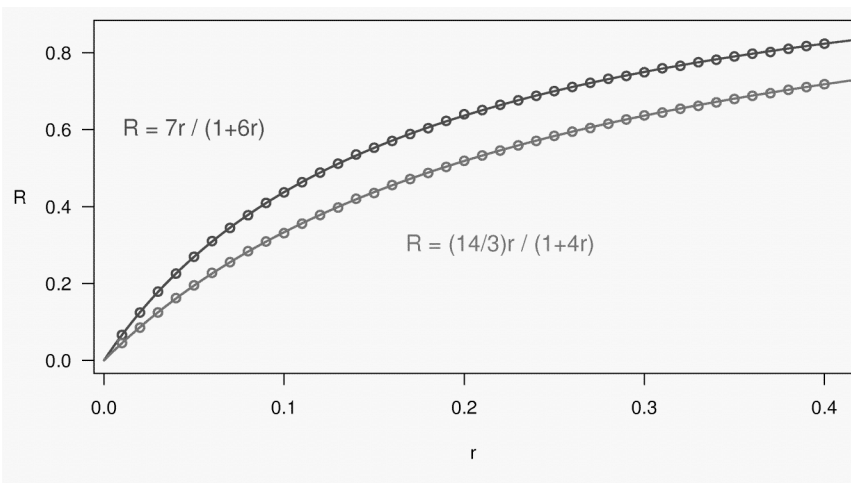

22

3-point coincidence

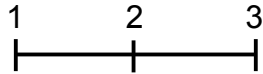

- r_{ij} = recombination fraction for interval i,j ;
assume $r_{12} = r_{23} = r$
- Coincidence = $c = \text{Pr}(\text{double recombinant}) / r^2$
 $= \text{Pr}(\text{rec'n in } 23 \mid \text{rec'n in } 12) / \text{Pr}(\text{rec'n in } 23)$
- No interference $\rightarrow = 1$
Positive interference $\rightarrow < 1$
Negative interference $\rightarrow > 1$
- Generally c is a function of r .

23

3-points in 2-way RILs



- $r_{13} = 2 r (1 - c r)$
- $R = f(r); \quad R_{13} = f(r_{13})$
- $\text{Pr}(\text{double recombinant in RIL}) = \{ R + R - R_{13} \} / 2$
- Coincidence (in 2-way RIL) = $\{ 2 R - R_{13} \} / \{ 2 R^2 \}$

24

Coincidence

No interference

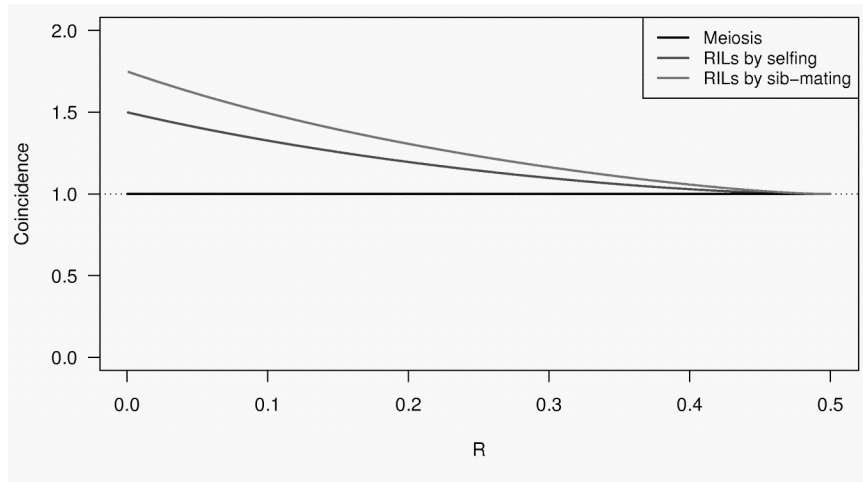

25

Coincidence

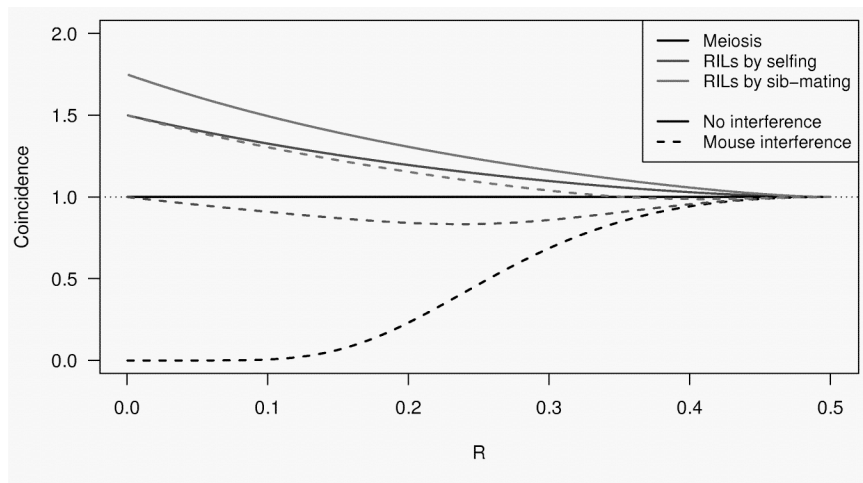

26

Why the clustering of breakpoints?

- The really close breakpoints occur in different generations.
- Breakpoints in later generations can occur only in regions that are not yet fixed.
- The regions of heterozygosity are, of course, surrounded by breakpoints.

27

Coincidence in 8-way RILs

- The trick that allowed us to get the coincidence for 2-way RILs doesn't work for 8-way RILs.
- It's sufficient to consider 4-way RILs.
- Calculations for 3 points in 4-way RILs is still astoundingly complex.
 - 2 points in 2-way RILs by sib-mating:
55 parental types → 22 states by symmetry
 - 3 points in 4-way RILs by sib-mating:
2,164,240 parental types → 137,488 states
- Even counting the states was difficult.

28

Coincidence

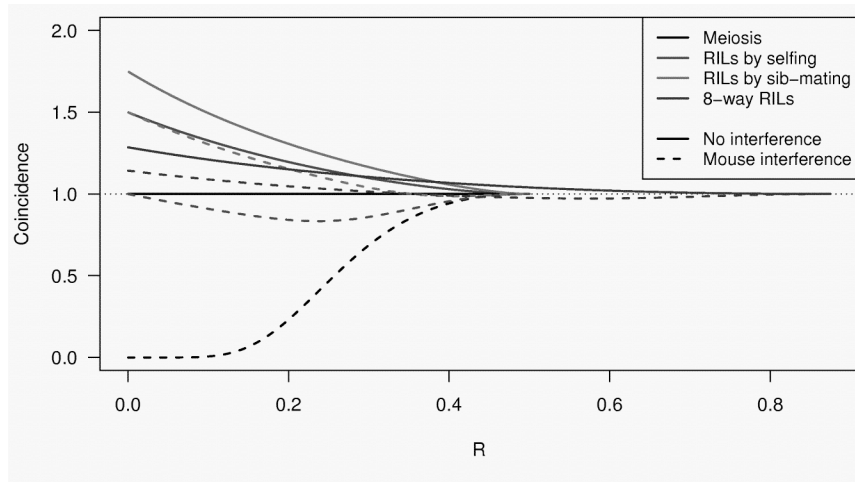

29

But there is an easier way...

30

Equations for sib-mating

Typical mating	Number of types	Equation
$AABB \times AABB$	2	$C_{n+1} = C_n + H + \frac{1}{2}(\alpha^2 + \gamma^2)L + \frac{1}{4}(\beta^2 + \delta^2)N + \frac{1}{2}Q + \frac{1}{2}R + \frac{1}{2}(\alpha^2 + \gamma^2)U + \frac{1}{2}(\beta^2 + \delta^2)V + \frac{1}{2}\alpha\beta^2W + \frac{1}{2}\gamma\delta^2X + \frac{1}{2}\alpha\beta\delta^2Y$
$AAbb \times AAbb$	2	$D_{n+1} = D + I + \frac{1}{2}(\alpha^2 + \gamma^2)M + \frac{1}{4}(\beta^2 + \delta^2)P + \frac{1}{2}Q + \frac{1}{2}S + \frac{1}{2}(\beta^2 + \delta^2)U + \frac{1}{2}(\alpha^2 + \gamma^2)V + \frac{1}{2}\alpha\beta^2W + \frac{1}{2}\gamma\delta^2X + \frac{1}{2}\alpha\beta\delta^2Y$
$AABB \times aabb$	2	$E_{n+1} = \frac{1}{2}\alpha\beta^2W + \frac{1}{2}\gamma\delta^2X + \frac{1}{2}\alpha\beta\delta^2Y$
$AAbb \times aaBB$	2	$F_{n+1} = \frac{1}{2}\alpha\beta^2W + \frac{1}{2}\gamma\delta^2X + \frac{1}{2}\alpha\beta\delta^2Y$
$AABB \times AAbb$	8	$G_{n+1} = \frac{1}{2}\alpha\beta(\alpha\beta + \gamma\delta)(U + V) + \frac{1}{2}\alpha\beta\gamma\delta(W + 2X + Y)$
$AAbb \times AaBB$	8	$H_{n+1} = \frac{1}{2}\alpha\beta(\alpha\beta + \gamma\delta)(U + V) + \frac{1}{2}\alpha\beta\gamma\delta(W + 2X + Y)$
$AAbb \times AaBb$	8	$I_{n+1} = \frac{1}{2}(\alpha\beta + \gamma\delta)U + \frac{1}{2}(\alpha\beta + \gamma\delta)V + \frac{1}{2}\alpha\beta\gamma\delta(W + 2X + Y)$
$AABB \times Aabb$	8	$J_{n+1} = \frac{1}{2}(\alpha\beta + \gamma\delta)U + \frac{1}{2}(\alpha\beta + \gamma\delta)V + \frac{1}{2}\alpha\beta\gamma\delta(W + 2X + Y)$
$AAbb \times AaBB$	8	$K_{n+1} = \frac{1}{2}(\alpha\beta + \gamma\delta)U + \frac{1}{2}(\alpha\beta + \gamma\delta)V + \frac{1}{2}\alpha\beta\gamma\delta(W + 2X + Y)$
$AABB \times Ab.aB$	4	$L_{n+1} = \frac{1}{2}(\alpha\beta + \gamma\delta)U + \frac{1}{2}(\alpha\beta + \gamma\delta)V + \frac{1}{2}\alpha\beta\gamma\delta(W + 2X + Y)$
$AAbb \times Ab.aB$	4	$M_{n+1} = \frac{1}{2}(\alpha\beta + \gamma\delta)U + \frac{1}{2}(\alpha\beta + \gamma\delta)V + \frac{1}{2}\alpha\beta\gamma\delta(W + 2X + Y)$
$AABB \times Ab.aB$	4	$N_{n+1} = \frac{1}{2}R + \frac{1}{2}(\alpha\beta + \gamma\delta)(U + V) + \frac{1}{2}\alpha\beta\gamma\delta(W + 2X + Y)$
$AAbb \times Ab.aB$	4	$P_{n+1} = \frac{1}{2}S + \frac{1}{2}(\alpha\beta + \gamma\delta)(U + V) + \frac{1}{2}\alpha\beta\gamma\delta(W + 2X + Y)$
$AAbb \times AaBb$	4	$Q_{n+1} = 2G + \frac{1}{2}(H + I + J + K) + \frac{1}{2}(\alpha^2 + \gamma^2)(L + M) + \frac{1}{2}(\beta^2 + \delta^2)(N + P) + \frac{1}{2}Q + \frac{1}{2}(R + S + T) + \frac{1}{2}(\alpha^2 + \alpha\beta + \beta^2 + \gamma^2 + \gamma\delta + \delta^2)(U + V) + \frac{1}{2}\alpha\beta(\alpha\beta + \gamma\delta)(W + Y) + \frac{1}{2}(\alpha\gamma + \beta\delta)X$
$AAbb \times AaBB$	4	$R_{n+1} = \frac{1}{2}(\beta^2 + \delta^2)L + \frac{1}{2}(\alpha^2 + \gamma^2)N + \frac{1}{2}R + \frac{1}{2}(\beta^2 + \delta^2)U + \frac{1}{2}(\alpha^2 + \gamma^2)V + \frac{1}{2}\alpha\beta(\alpha\beta + \gamma\delta)(W + Y) + \frac{1}{2}(\alpha\gamma + \beta\delta)X$
$AAbb \times Aabb$	4	$S_{n+1} = \frac{1}{2}(\beta^2 + \delta^2)M + \frac{1}{2}(\alpha^2 + \gamma^2)P + \frac{1}{2}S + \frac{1}{2}(\alpha^2 + \gamma^2)U + \frac{1}{2}(\beta^2 + \delta^2)V + \frac{1}{2}\alpha\beta(\alpha\beta + \gamma\delta)(W + Y) + \frac{1}{2}(\alpha\gamma + \beta\delta)X$
$AAbb \times aaBb$	4	$T_{n+1} = \frac{1}{2}(\alpha\beta + \gamma\delta)(U + V) + \frac{1}{2}\alpha\beta(\alpha\beta + \gamma\delta)(W + Y) + \frac{1}{2}(\alpha\gamma + \beta\delta)X$
$AAbb \times Ab.aB$	8	$U_{n+1} = \frac{1}{2}(\alpha\beta + \gamma\delta)(L + N) + \frac{1}{2}(S + T) + \frac{1}{2}(\alpha^2 + \gamma^2)U + \frac{1}{2}(\beta^2 + \delta^2)V + \frac{1}{2}\alpha\beta(\alpha\beta + \gamma\delta)(W + Y) + \frac{1}{2}(\alpha\gamma + \beta\delta)X$
$AAbb \times Ab.aB$	8	$V_{n+1} = \frac{1}{2}K + \frac{1}{2}(\alpha\beta + \gamma\delta)(M + P) + \frac{1}{2}(R + T) + \frac{1}{2}(\beta^2 + \delta^2)U + \frac{1}{2}(\alpha^2 + \gamma^2)V + \frac{1}{2}\alpha\beta(\alpha\beta + \gamma\delta)(W + Y) + \frac{1}{2}(\alpha\gamma + \beta\delta)X$
$Ab.ab \times Ab.aB$	1	$W_{n+1} = 2(E + J) + \frac{1}{2}(\alpha^2 + \gamma^2)L + \frac{1}{2}(\beta^2 + \delta^2)N + \frac{1}{2}(S + T) + \frac{1}{2}(\alpha^2 + \gamma^2)U + \frac{1}{2}(\beta^2 + \delta^2)V + \frac{1}{2}\alpha\beta^2W + \frac{1}{2}\gamma\delta^2X + \frac{1}{2}\alpha\beta\delta^2Y$
$Ab.ab \times Ab.aB$	2	$X_{n+1} = \frac{1}{2}T + \frac{1}{2}(\alpha\beta + \gamma\delta)(U + V) + \frac{1}{2}\alpha\beta\gamma\delta(W + 2X + Y)$
$Ab.ab \times Ab.aB$	1	$Y_{n+1} = 2(F + K) + \frac{1}{2}(\alpha^2 + \gamma^2)M + \frac{1}{2}(\beta^2 + \delta^2)P + \frac{1}{2}(R + T) + \frac{1}{2}(\beta^2 + \delta^2)U + \frac{1}{2}(\alpha^2 + \gamma^2)V + \frac{1}{2}\alpha\beta^2W + \frac{1}{2}\gamma\delta^2X + \frac{1}{2}\alpha\beta\delta^2Y$

31

The simpler method

Consider the cross $W_1W_2|X_1X_2 \times Y_1Y_2|Z_1Z_2$

Let $q_1 = \Pr(W_1W_2 \text{ fixed})$
 $q_2 = \Pr(W_1X_2 \text{ fixed})$
 $q_3 = \Pr(W_1Y_2 \text{ fixed})$

Then $4q_1 + 4q_2 + 8q_3 = 1$

First generation: $W_i = X_i = A, Y_i = Z_i = B$

Then $\Pr(AA \text{ fixed}) = 2(q_1 + q_2)$
 $\Pr(AB \text{ fixed}) = 4q_3$

32

The simpler method

$$W_1W_2|X_1X_2 \times Y_1Y_2|Z_1Z_2$$

$$q_1 = \Pr(W_1W_2 \text{ fixed}) \quad q_2 = \Pr(W_1X_2 \text{ fixed}) \quad q_3 = \Pr(W_1Y_2 \text{ fixed})$$

Second generation: $W_i = Y_i = A, X_i = Z_i = B$

$$\text{Then } \Pr(AA \text{ fixed}) = 2(q_1 + q_3)$$

$$\text{Thus } q_2 = q_3$$

33

The simpler method

$$W_1W_2|X_1X_2 \times Y_1Y_2|Z_1Z_2$$

$$q_1 = \Pr(W_1W_2 \text{ fixed}) \quad q_2 = \Pr(W_1X_2 \text{ fixed}) \quad q_3 = \Pr(W_1Y_2 \text{ fixed})$$

Now we use the usual trick, condition on the first step:

$$q_1 = (1 - r)/2 \times q_1 \times 4 + 1/2 \times 1/2 \times q_2 \times 12$$

Combined with the previous results, we get

$$q_2 = r/[2(1+6r)]$$

$$\text{And so } \Pr(AB \text{ fixed}) = 4q_3 = 4r/(1+6r)$$

34

The formula

$$C = (1+6r) \frac{280 + 1280r - 848r^2 + 5c(7 - 28r - 368r^2 + 344r^3) - 2c^2(49 - 324r + 452r^2)r^2 - 16c^3(1 - 2r)r^4}{49(1+12r - 12cr^2)[5 + 10r - 4(2+c)r^2 + 8cr^3]}$$

35

3-point symmetry

$$\Pr(M_2 = x \mid M_1 = A, M_2 \neq A, M_3 = A)$$

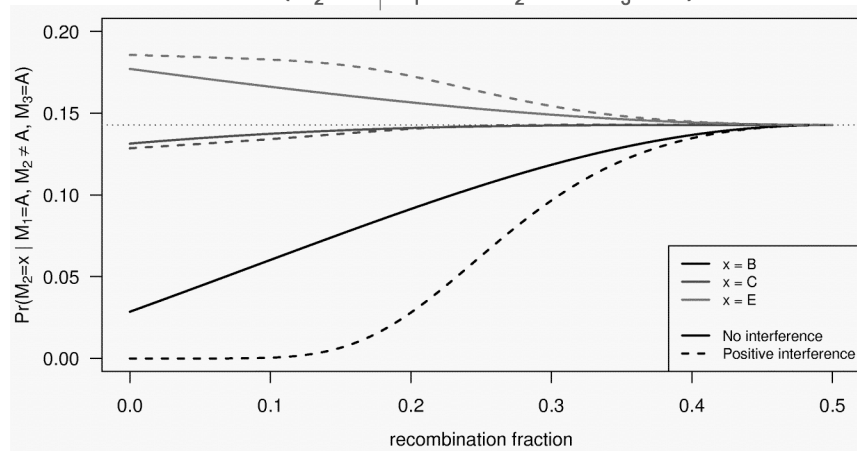

36

Markov property

$$\log_2 \left\{ \frac{\Pr(M_3 = A \mid M_2 = A, M_1 = x)}{\Pr(M_3 = A \mid M_2 = A)} \right\}$$

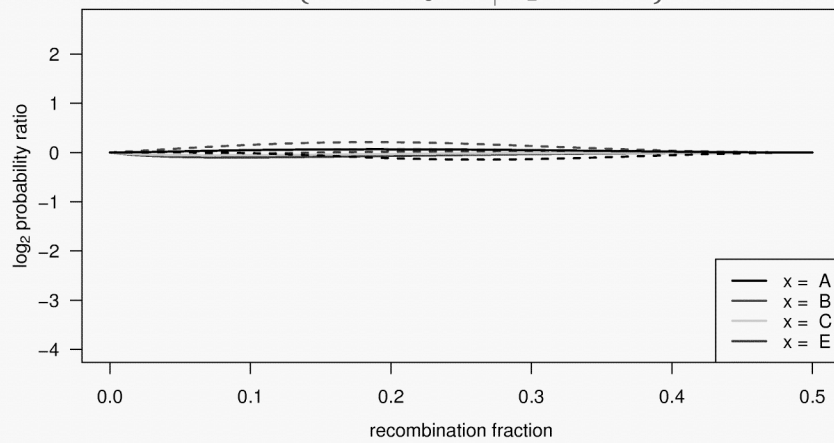

37

Markov property

$$\log_2 \left\{ \frac{\Pr(M_3 = A \mid M_2 = B, M_1 = x)}{\Pr(M_3 = A \mid M_2 = B)} \right\}$$

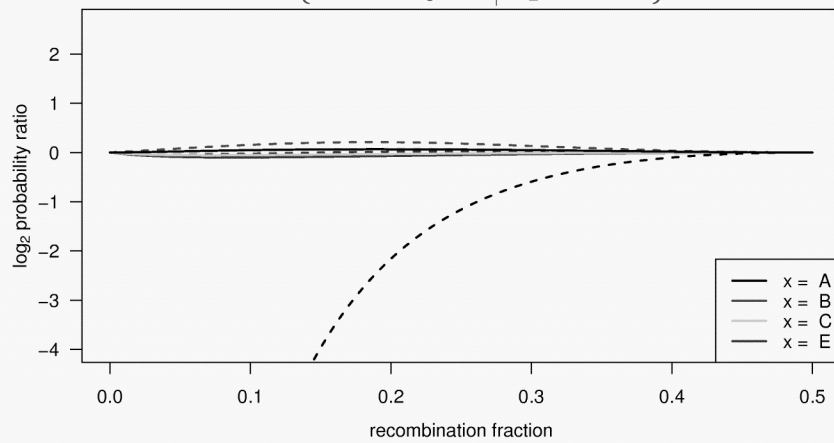

38

Markov property

$$\log_2 \left\{ \frac{\Pr(M_3 = A \mid M_2 = C, M_1 = x)}{\Pr(M_3 = A \mid M_2 = C)} \right\}$$

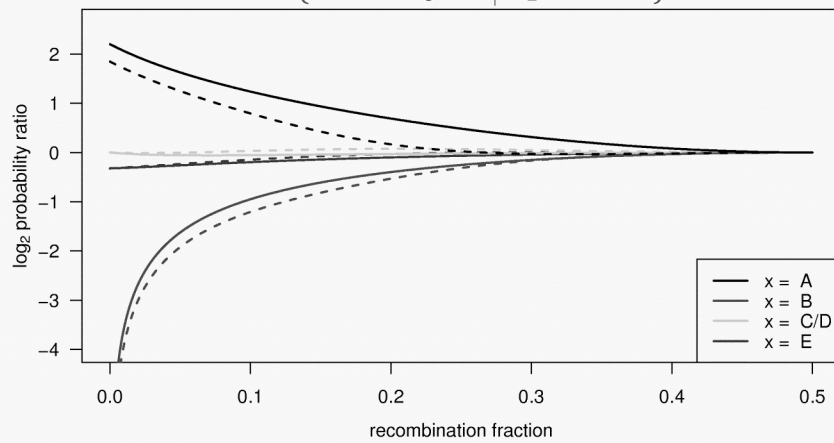

39

Markov property

$$\log_2 \left\{ \frac{\Pr(M_3 = A \mid M_2 = E, M_1 = x)}{\Pr(M_3 = A \mid M_2 = E)} \right\}$$

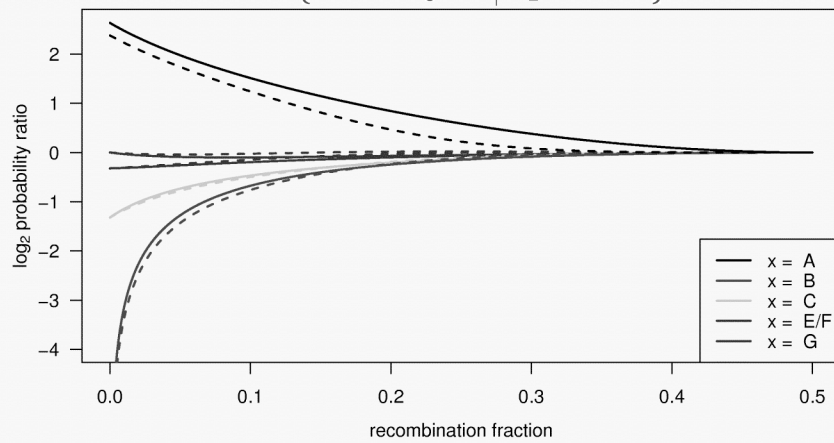

40

Whole genome simulations

- 2-way selfing, 2-way sib-mating, 8-way sib-mating
- Mouse-like genome, 1665 cM
- Strong positive crossover interference
- Inbreed to complete fixation
- 10,000 simulation replicates

41

No. generations to fixation

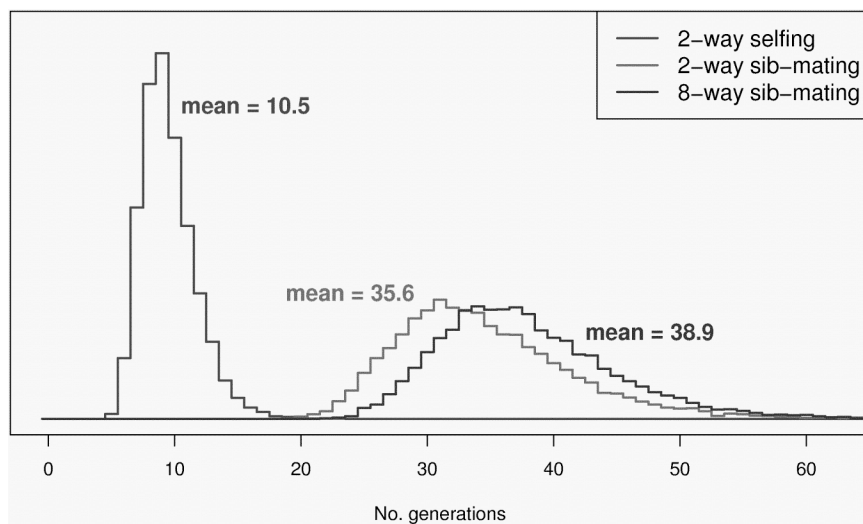

42

No. gen's to 99% fixation

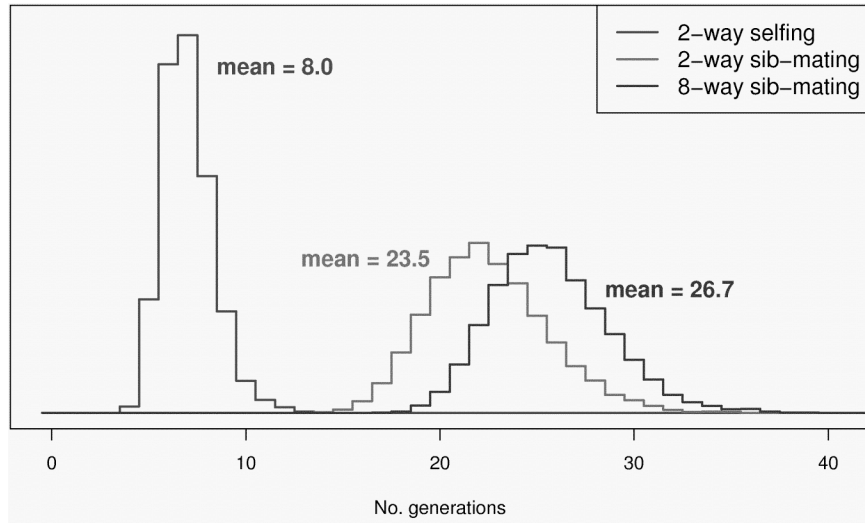

Percent genome not fixed

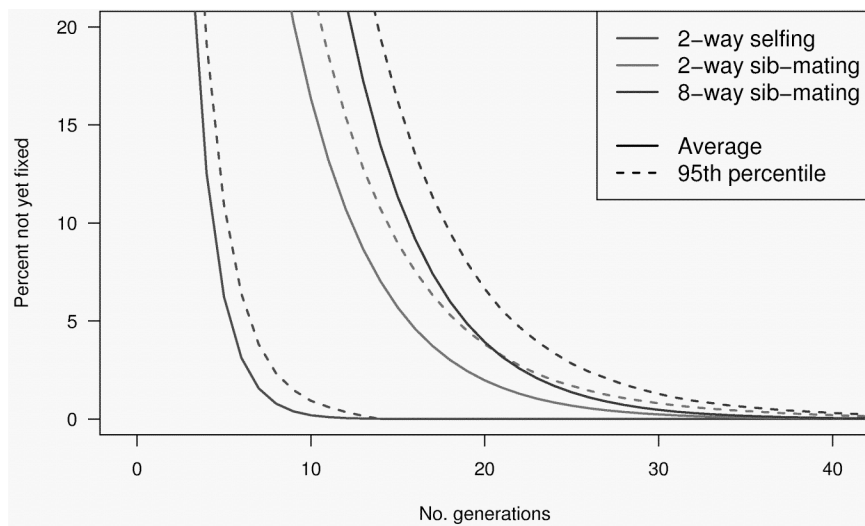

Number of breakpoints

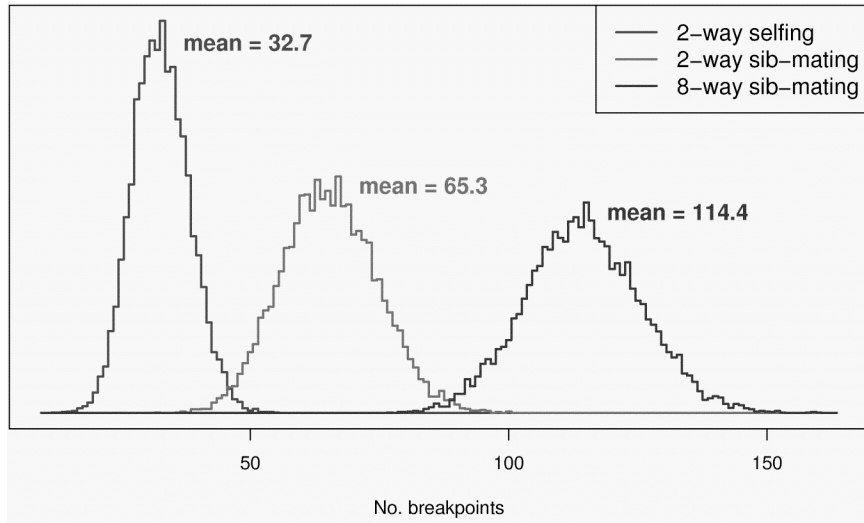

Segment lengths

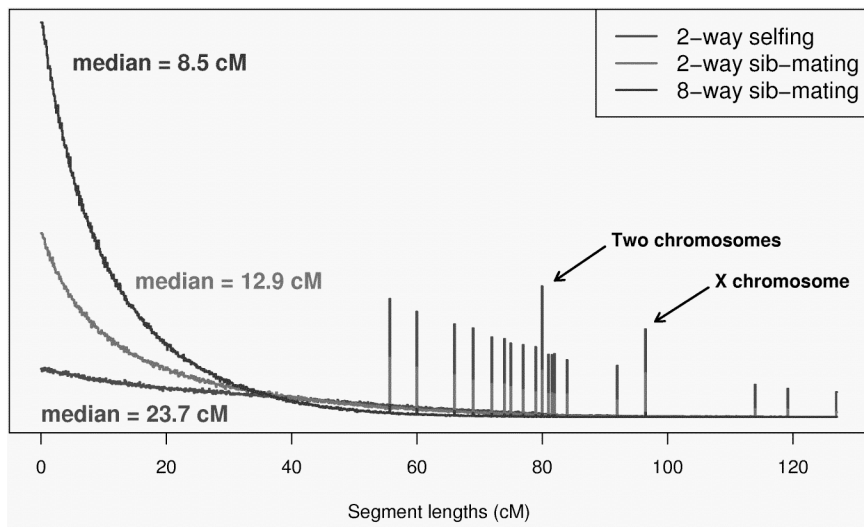

Probability a segment is inherited intact

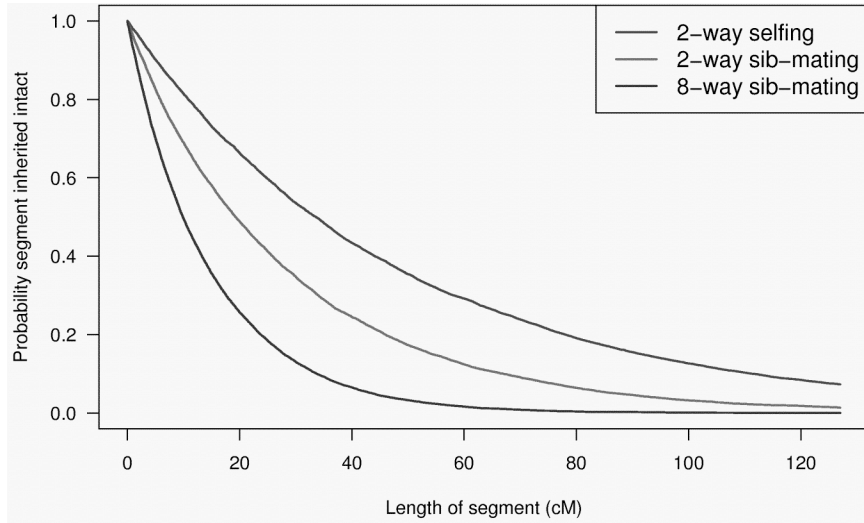

47

Length of smallest segment

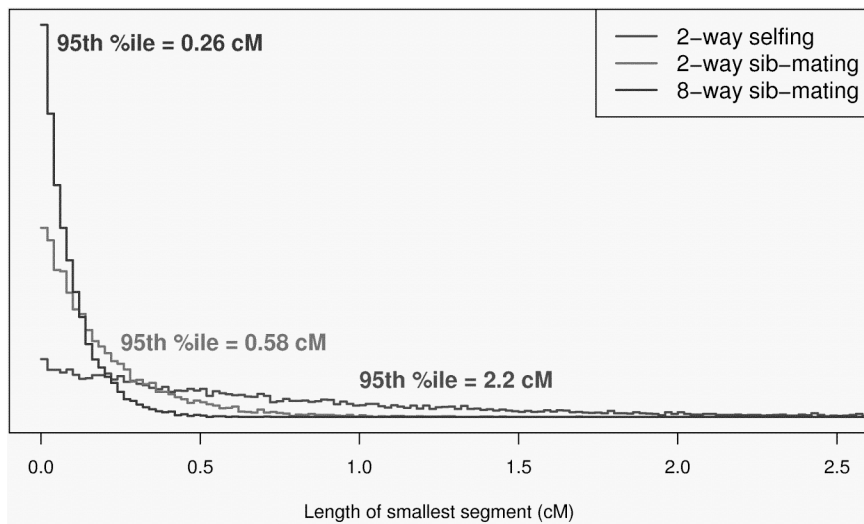

48

No. segments < 1 cM

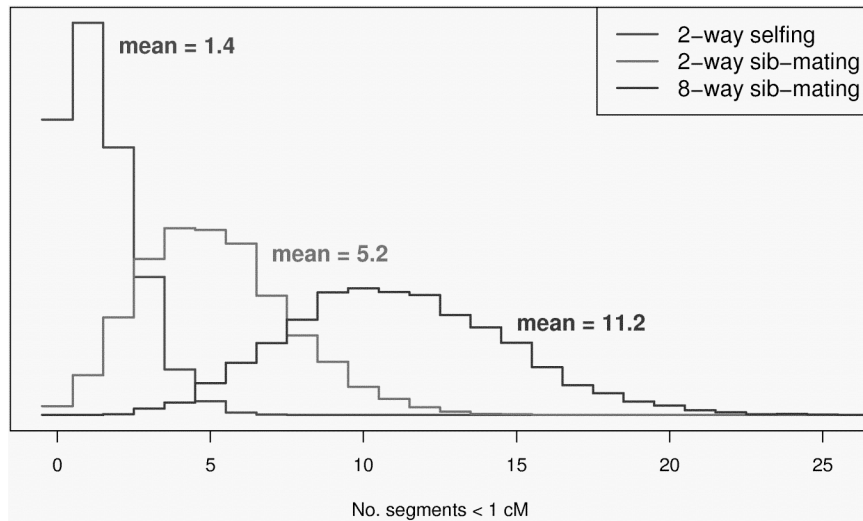

Summary

- The Collaborative Cross could provide “one-stop shopping” for gene mapping in the mouse.
- Use of such 8-way RILs requires an understanding of the breakpoint process.
- We’ve extended Haldane & Waddington’s results to the case of 8-way RILs: $R = 7r / (1 + 6r)$.
- We’ve shown clustering of breakpoints in RILs by sib-mating, even in the presence of strong crossover interference.
- Broman KW (2005) The genomes of recombinant inbred lines. *Genetics* 169:1133-1146

Acknowledgement

Friedrich Teuscher

Research Institute for the Biology of Farm Animals
Dummerstorf, Germany