

# A Common Locus for Late-Onset Fuchs Corneal Dystrophy Maps to 18q21.2-q21.32

Olof H. Sundin,<sup>1,2</sup> Karl W. Broman,<sup>3</sup> Howard H. Chang,<sup>3</sup> Elizabeth C. L. Vito,<sup>1</sup> Walter J. Stark,<sup>1</sup> and John D. Gottsch<sup>1</sup>

**PURPOSE.** To identify the genetic basis of late-onset Fuchs corneal dystrophy (FCD).

**METHODS.** Phenotypes and genotypes at 1107 short tandem repeat polymorphism markers were obtained for 43 affected and 33 unaffected individuals in three large families. Two-point genetic linkage analysis was performed with MLINK and multipoint linkage with SimWalk 2.89.

**RESULTS.** In each family, the most significant cluster of two-point lod scores mapped to chromosome 18, at 18q21.2-q21.3. The highest two-point lod score for each family was at *D18S1129*, with scores of 3.41, 2.89, and 2.45, with a combined two-point lod score of 7.70. Multipoint analysis yielded a maximum score of 5.94 at *D18S1129* for a dominant Mendelian trait exhibiting 85% penetrance and 15% phenocopy rate. Disease interval haplotypes for each family are different.

**CONCLUSIONS.** *FCD2*, at 18q21, is the second genetic locus identified for late-onset FCD. Presence of this same locus in all three families may indicate its widespread involvement in late-onset FCD. Allelic differences between disease-associated haplotypes in the families leave open the possibility of independent mutations in the same gene. The incomplete penetrance and high phenocopy rate observed at *FCD2* suggest that the origin of FCD in these three families is complex and also depends on other genetic loci or environmental factors. (*Invest Ophthalmol Vis Sci.* 2006;47:3919-3926) DOI:10.1167/iov.05-1619

Fuchs corneal dystrophy (FCD), first described in the early 20th century,<sup>1,2</sup> is a common age-related disorder that affects 4% of those older than 40 years.<sup>3</sup> In its early stages, FCD is characterized by the formation of guttae, which are microscopic excrescences of Descemet's membrane, the basal lamina that underlies the corneal endothelium.<sup>4,5</sup> FCD typically begins in the fifth decade of life and progresses slowly over two to three decades.<sup>6,7</sup> End-stage disease is characterized by degeneration of the corneal endothelium,<sup>8-10</sup> with the conse-

quent failure of its ion transport and solute barrier functions.<sup>11,12</sup>

Although examples of familial FCD are well known,<sup>12-15</sup> attempts to identify loci and genes have only recently achieved results.<sup>7,16,17</sup> A rare, atypical form of inherited FCD that is characterized by unusual corneal histopathology and onset in early childhood<sup>18</sup> has been mapped to the *FECD* locus at 1p34 and associated with point mutations in the *COL8A2* gene.<sup>7,16</sup> This gene encodes the  $\alpha 2$  subtype of collagen VIII, a major component of Descemet's membrane, the thick basal lamina underlying the corneal endothelium.<sup>19-21</sup> Even though this early-onset disorder has provided important insights into the etiology of FCD,<sup>7,16,18</sup> we still have no clear evidence that mutations of *COL8A2* are involved in the common late-onset form of the disease.<sup>22</sup>

We have recently identified *FCD1*, a disease locus for late-onset FCD that maps to 13pter-13q21.13.<sup>23</sup> The *FCD1* kindred exhibited single-locus Mendelian inheritance with high penetrance, despite the prevailing view that multiple low-penetrance genetic traits modified by environmental factors are generally thought to underlie common human diseases.<sup>24,25</sup> It is still unknown whether single-locus or more complex inheritance is typical of this disease. Although relatively few large families have been reported,<sup>13,14,26</sup> familial FCD appears to be common, as 50% of clinical patients with FCD are found to have siblings, parents, or offspring with the disease.<sup>6,7</sup> To address the genetic basis of FCD more broadly, we now report the results of genetic linkage analysis for three large families showing dominant inheritance of late-onset FCD.

## METHODS

### Patients and Determination of Phenotype

Participants in this study were recruited, examined, and their written consent obtained under authorization of the Institutional Review Board for Human Subjects Research at the Johns Hopkins University School of Medicine, according to principles of the Declaration of Helsinki. Diagnosis of FCD was by slit lamp biomicroscopy<sup>7</sup> and was graded according to the scale of Krachmer et al.<sup>6</sup> Definitive onset of the disease was indicated by 12 or more central, nonconfluent guttae in at least one eye. Confocal specular microscopy,<sup>27</sup> to examine the morphology of guttae, was performed in selected patients in the clinic, as previously described<sup>7</sup> (ConfoScan3 microscope; Nidek Technologies, Vigonza, Italy).

### Genotyping and Linkage Analysis

Whole blood was obtained from family members and stored at  $-20^{\circ}\text{C}$ . DNA from 3.5 mL blood was extracted with a genomic DNA kit (Wizard; Epicenter, Madison, WI) and genotyped by deCode Genetics (Reykjavik, Iceland) at 1107 polymorphic tandem repeat linkage markers distributed at  $\sim 4$  cM spacing over all autosomes and the X chromosome.<sup>28</sup> Pedigree integrity was checked with Relcheck.<sup>29</sup> Paternity for all family members was confirmed, and Mendelian consistency of all genotypes were tested by Pedcheck.<sup>30</sup> Only 149 genotypes, representing 0.15% of total genotypes, showed Mendelian inconsistency due to

From the <sup>1</sup>Center for Corneal Genetics, Cornea and External Disease Service, and the <sup>2</sup>Laboratory of Developmental Genetics, The Wilmer Eye Institute, Johns Hopkins University School of Medicine, Baltimore, Maryland; and the <sup>3</sup>Department of Biostatistics, Johns Hopkins Bloomberg School of Public Health, Baltimore, Maryland.

Supported by the Faller Family LLC Fund. Departmental core facilities were in part supported by an unrestricted grant from Research to Prevent Blindness.

Submitted for publication December 19, 2005; revised March 3, 2006; accepted June 23, 2006.

Disclosure: O.H. Sundin, None; K.W. Broman, None; H.H. Chang, None; E.C.L. Vito, None; W.J. Stark, None; J.D. Gottsch, None

The publication costs of this article were defrayed in part by page charge payment. This article must therefore be marked "advertisement" in accordance with 18 U.S.C. §1734 solely to indicate this fact.

Corresponding author: John D. Gottsch, 321 Maumenee Building, The Wilmer Eye Institute, Johns Hopkins Hospital, 600 N. Wolfe Street, Baltimore, MD 21287; jgottsch@jhmi.edu.

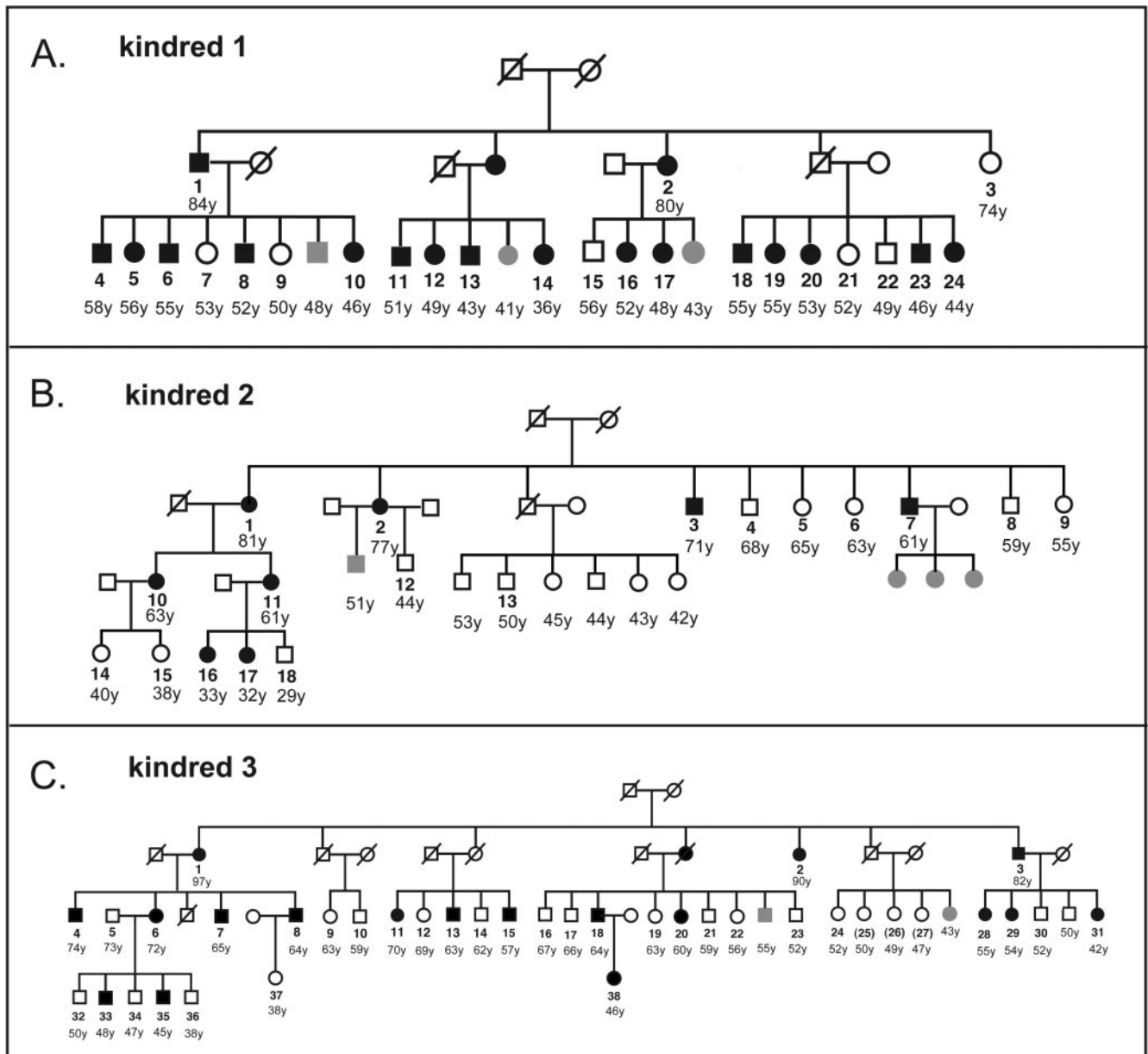
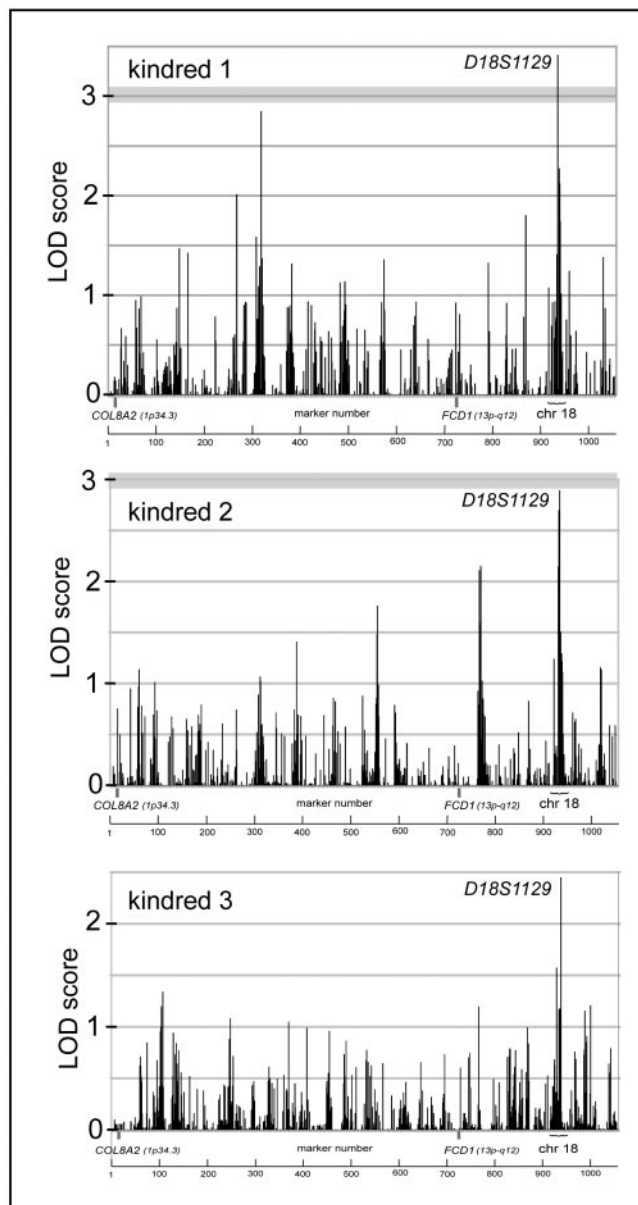

**FIGURE 1.** Three large pedigrees with pronounced clustering of FCD. Selected individuals are numbered for reference, and ages are indicated for those in whom there was a clear diagnosis of the presence (*solid symbols*) or absence (*open symbols*) of FCD. *Shaded symbols*: not ascertained and of unknown phenotype. These individuals did not participate in the linkage analysis. It should be noted that these three families have been selected only on the basis of their size and strong familial clustering of late-onset FCD.

genotyping error and were removed. Two-point linkage mapping was performed with MLINK,<sup>31</sup> using a model that assumed fully penetrant Mendelian inheritance with disease allele frequency 0.0001. Multipoint linkage and haplotypes were obtained using SimWalk 2.89 (<http://www.simwalk@genetics.ucla.edu/>) provided in the public domain by the University of California Los Angeles.<sup>32</sup> Multipoint analysis was performed in a reduced-penetrance model, having penetrances of  $f_0$ ,  $f_1$ , and  $f_2 = 0.15, 0.85,$  and  $0.85$ , where  $f_i$  is the chance that an individual carrying  $i$  disease alleles will be affected. The disease allele frequency was set to 0.0001. Marker allele frequencies used in the calculations were estimated directly from the linkage population. Simulated linkage results were obtained by averaging 100 independent runs of MLINK with randomly generated alleles for genotyped individuals.

## RESULTS

The three largest late-onset FCD pedigrees available for study were ascertained as completely as possible, in preparation for linkage analysis (Fig. 1). Selected individuals were examined fully by means of slit lamp and high-resolution confocal specular microscopy and were found to have corneal guttae with a morphology typical of classic late-onset FCD.<sup>7,27</sup> Together, the three families had 27 affected women, and 19 affected men. Among those affected, the youngest was age 32, the oldest 97. The presence of FCD patients in multiple generations, and a high percentage of affected siblings was consistent with dominant inheritance, the model implemented with two-point parametric MLINK linkage analysis, and subsequent multipoint link-



**FIGURE 2.** Two-point lod score genome scans of each kindred. Lod scores of the pedigrees in Figure 1 were obtained for 1056 autosomal markers by using MLINK. The mutant was assumed to be a fully penetrant Mendelian dominant trait with an allele frequency of 0.0001. The recombination fraction  $\theta$  was allowed to vary for each point, to achieve a maximum lod score. Markers are organized in chromosomal linkage groups, beginning with chromosome 1 on the left and proceeding from the short arm (p) toward the long arm (q) on each chromosome. Brackets indicate selected chromosomes. Markers corresponding to the two known FCD loci for COLA2 (*FECD*; 1p34) and *FCD1* (13pter-q12.13) are indicated by vertical bars beneath the graph. The marker *D18S1129* repeatedly gave the single highest lod score within each of the three kindreds.

age. Initial results of whole-genome scans of the three families by two-point linkage analysis, assuming fully penetrant dominant single-locus Mendelian inheritance, are shown in Figure 2. Note that these lod scores are calculated at the maximum-likelihood estimate of the recombination fraction  $\theta$  between each marker and the putative disease gene, with  $\theta$  construed to be the same in all families. In all three of the families, a major

peak was found on chromosome 18, with the top lod score at *D18S1129* in each case. In kindreds 1, 2, and 3, this peak had maximum lod values of 3.41, 2.89, and 2.45, respectively (Table 1). Other two-point linkage peaks were also observed, although none were found for polymorphic markers near the *COLA2* gene at 1p34 or within the *FCD1* locus at 13pter-q12 (Fig. 2).

The combined linkage statistics for all three families was estimated by summation of the two-point lod scores for each marker calculated using a single value of  $\theta$ , then maximizing this combined score across different values of  $\theta$  (Fig. 3). The 18q21 locus showed a cluster of very high cumulative lod scores, with a two-point lod score of 7.70 for *D18S1129*. Secondary peaks on other chromosomes were also observed, but the significance of these is unclear, as they differed among the families. None of the secondary peaks corresponded to the two previously characterized loci for this disease, *FECD* (*COLA2*) at 1p34<sup>7,16</sup> or *FCD1* at 13pter-q12.13<sup>23</sup> (see Fig. 2). These results were extremely robust over different estimates of the disease allele frequency, which altered the peak *D18S1129* lod score from 7.70 at a frequency of 0.0001 to 7.73 at a frequency of 0.01.

Multipoint lod scores were calculated for all 35 markers on chromosome 18 in a dominant model with penetrance of 85% and a phenocopy rate of 15% (Fig. 4A), as described in the Methods section. These traces revealed maxima at *D18S1129* for all three families, whereas the combined scores produced a highly significant lod score peak of 5.94 at this marker. Because multipoint analysis is relatively insensitive to misspecification of marker allele frequencies, this peak provides strong confirmation of the significance of the cluster of high two-point lod scores seen in Figure 3. The observed phenocopy rate in these families is 22%, much higher than the 4% prevalence conservatively estimated for the general population. If the multipoint linkage is determined with a 5% phenocopy parameter (Fig. 5B), the results are very similar, with a peak combined lod score of 5.51, and the background level for unlinked markers is considerably lower.

Multipoint analysis also yielded inferred haplotypes for each of the three families. These are shown in Figures 5, 6, and 7 along with pedigree structure and disease phenotype. In kindred 1, the 18q21 locus disease haplotype (boxed) showed strong correlation with the disease, although three phenocopies were observed in which the disease was not accompanied by the disease-associated haplotype (Fig. 5). Over all three families there were eight obligatory phenocopies in 36 individuals with no disease (Table 2). An example of nonpenetrance is illustrated by unaffected family member 3 (Fig. 5). Kindred 2 also showed high penetrance (Fig. 6), whereas kindred 3 (Fig. 7) revealed weaker but still substantial association with the disease. Over all three families, there were 41 disease haplotypes, and only four of the individuals carrying the disease haplotype were unaffected, for an observed penetrance rate of 90% for the disease trait, assuming a dominant model of inheritance. When the disease haplotypes of each family were compared by amplicon length (Table 3), they revealed that *D18S1152*, *D18S64*, and *D18S1134* had identical alleles in kindreds 1 and 2, but that kindred 3 shared disease haplotype alleles with the other two families at only *D18S1134*.

## DISCUSSION

A single locus centered at 18q21.2-q21.32 appears to be the major determining genetic factor for FCD in the three large kindreds analyzed in this study. This was unexpected, because the only genetic prescreening done before genome scan anal-

TABLE 1. Two-Point LOD Scores of Consecutive Markers at the 18q21 Locus

Marker Name	Loc. (cM)	Maximum Lod Scores for Each Family			Maximum Sum of Lod Scores	
		Kin 1	Kin 2	Kin 3	Max (1+2+3)	Estimated $\theta$
<i>D18S487</i>	76.15	+1.41	+2.70	+1.18	+4.90	0.14 (14 cM)
<i>D18S1152</i>	80.41	0.00	+2.58	+1.01	+3.15	0.15 (15 cM)
<i>D18S1129</i>	83.46	+3.41	+2.89	+2.45	+7.70	0.11 (11 cM)
<i>D18S64</i>	84.80	0.00	+1.27	+0.17	+1.07	0.25 (25 cM)
<i>D18S1134</i>	88.62	+0.05	+1.50	+0.06	+1.17	0.23 (23 cM)

Columns contain the marker name, location of each marker on the chromosome 18 linkage group in centimorgans, two-point lod scores for each of the three kindreds and combined lod score for all three kindreds, with the value of  $\theta$  at the maximum combined lod score. That  $\theta$  is in each case greater than the spacing between the markers suggests that a fully penetrant model is not the best fit for the data.

ysis was performed to rule out known loci, the late-onset *FCD1* locus at 13pter-q12<sup>23</sup> and the *COL8A2* gene at 1p34.<sup>24</sup> These three families were selected purely on the basis of their size and a pronounced clustering of FCD cases. This finding suggests that 18q21 is a common locus in families showing dominant inheritance of late-onset FCD. Heterogeneity of the disease haplotypes between the three families leaves open the possibility of independent mutations at this locus. We cannot yet rule out that all three kindreds share a single ancient mutation that has undergone extensive recombination with its flanking markers.

Two-point linkage of the combined families yielded surprisingly large maximum two-point lod scores at *D18S1129*. In this case, lod scores were calculated for isolated markers in a dominant, completely penetrant model, with the recombination fraction  $\theta$  between the marker and the disease locus allowed to vary. Two-point linkage analysis is generally robust to misspecification of the genetic model (the penetrances and disease allele frequency), though the estimated recombination fraction between the marker and the disease locus will generally be biased. For a discussion of the effects of model mis-

specification in linkage analysis the reader is referred to Sham 1998 (Ref. 33, pp 95-97). Thus, the fact that the estimated  $\theta$  were larger than the actual distances between the markers (Table 1) suggests that the data are inconsistent with fully penetrant inheritance of the trait. This map-related inconsistency was confirmed by multipoint analysis of the same data, which yielded no significant linkage for chromosome 18 when calculated using a fully penetrant dominant model of inheritance (not shown). However, multipoint linkage yielded highly significant linkage to *D18S1129* when 85% penetrance and a 15% phenocopy rate were incorporated into the dominant inheritance model (Fig. 4A). When the phenocopy rate was set close to the observed sporadic incidence of FCD in the general population (reference level), there was only a minor decrease in the peak score from 5.94 to 5.51. Although multiple linkage analysis is not robust to misspecification of the genetic model, neither two-point nor multipoint linkage analysis give increased false-positive rates in the presence of model misspecification,<sup>33</sup> and so the linkage evidence in these kindreds provides extremely strong support for the contribution of the chromosome 18 locus to Fuchs susceptibility.

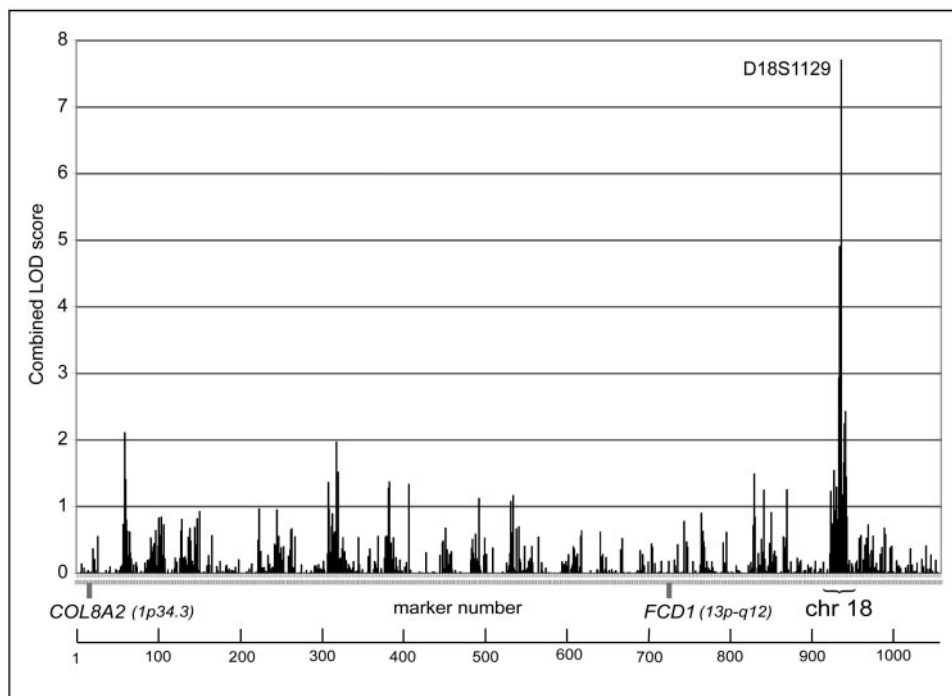
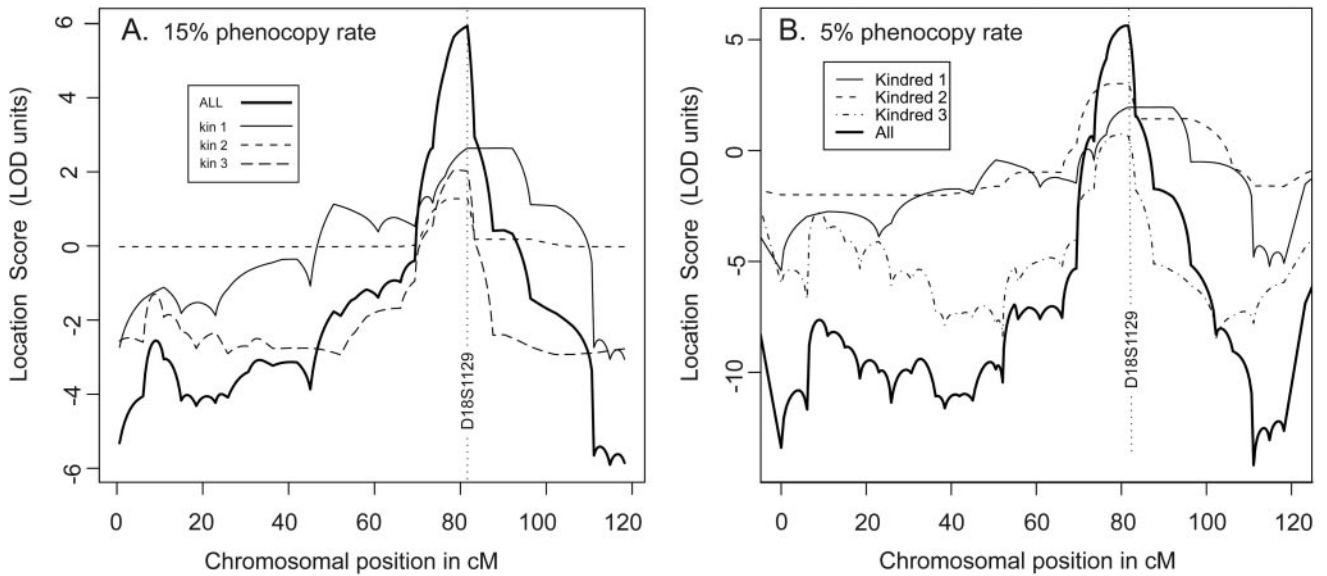

FIGURE 3. Combined two-point lod scores for all three families. The combined lod score at each marker was the sum of the lod scores in the three families, evaluated at the maximum likelihood estimate of the recombination fraction  $\theta$  which was construed to be the same in all families. The maximum combined lod score of 7.70 was obtained for *D18S1129*.



**FIGURE 4.** Multipoint linkage to chromosome 18. Multipoint linkage using all 35 markers on chromosome 18, calculated with SimWalk 2.89. The lod score was plotted against the Marshfield map position of markers in centimorgans (p to q). *Lines*: individual results for each family, according to the key. *Bold solid curve*: combined multipoint lod score for all three families. All calculations were based on an assumed mutant allele frequency of 0.0001, Mendelian dominant inheritance with 85% penetrance (mutant genotype with normal phenotype) with a phenocopy rate of (A) 15% or (B) 5%. The maximum combined lod score is 5.94 for a 15% phenocopy rate and 5.48 for a 5% phenocopy rate. Each peak is at *D18S1129*, indicated by a vertical dotted line.

When haplotypes and disease diagnoses were examined on an individual-by-individual basis, deviations from ideal Mendelian inheritance were apparent. Of the 41 individuals with the full three-marker disease haplotype, four were clearly not affected by FCD (Table 2), an observed 90% penetrance of the *FCD2* mutation. Lack of penetrance of the mutation in individual 3 of kindred 1, who was 74 years old, is not readily

explained as an age-of-onset effect, and the number of cases in this study was too small to allow us to draw any conclusions. As a common disease, we would expect FCD to show complex inheritance, and it is something of a surprise that the observed penetrance rate is as high as 90%. This suggests that environmental or other genetic factors are relatively minor modifiers of the inherited disease trait in these particular families. However,

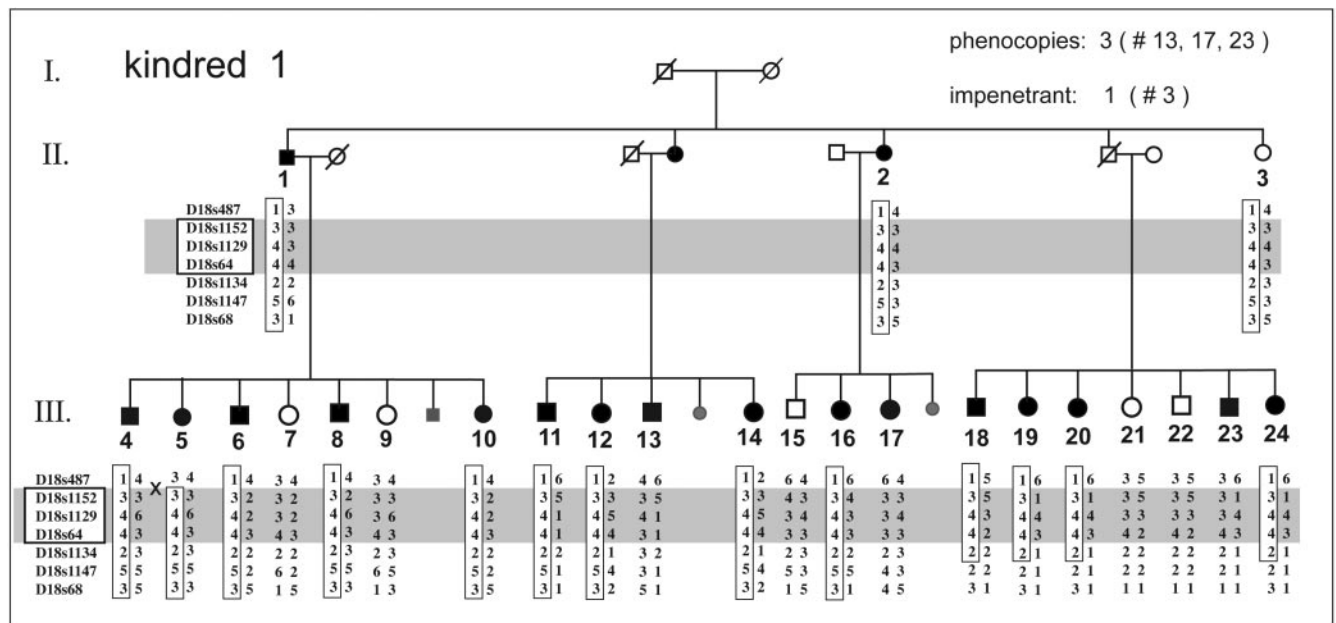

**FIGURE 5.** Haplotype analysis of kindred 1. Genotypes are indicated for markers around the chromosome 18 major linkage peak at *D18S1129*. Alleles are encoded in order of decreasing amplicon size in this family, with 0 signifying unknown or undeterminable genotype. *Boxes* enclose the haplotype of the FCD-associated chromosome, assuming a dominant, incompletely penetrant model of inheritance, with a high phenocopy rate. *Gray bar*: the disease-associated markers for all three families. Individuals representing phenocopies and those showing nonpenetrance of the disease trait are indicated at *top right*.

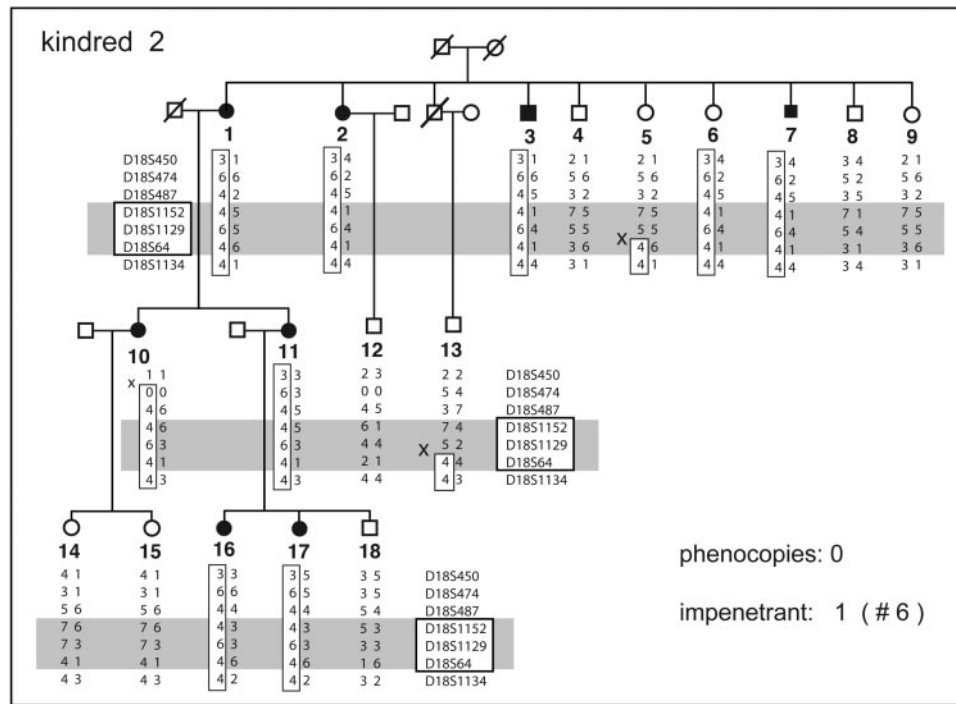

**FIGURE 6.** Haplotype of kindred 2. Haplotypes are displayed as in Figure 5. Individual 13 showed impenetrance at only *D18S64*, but was not counted as an obligatory case of impenetrance, as the disease locus boundary could be above this marker.

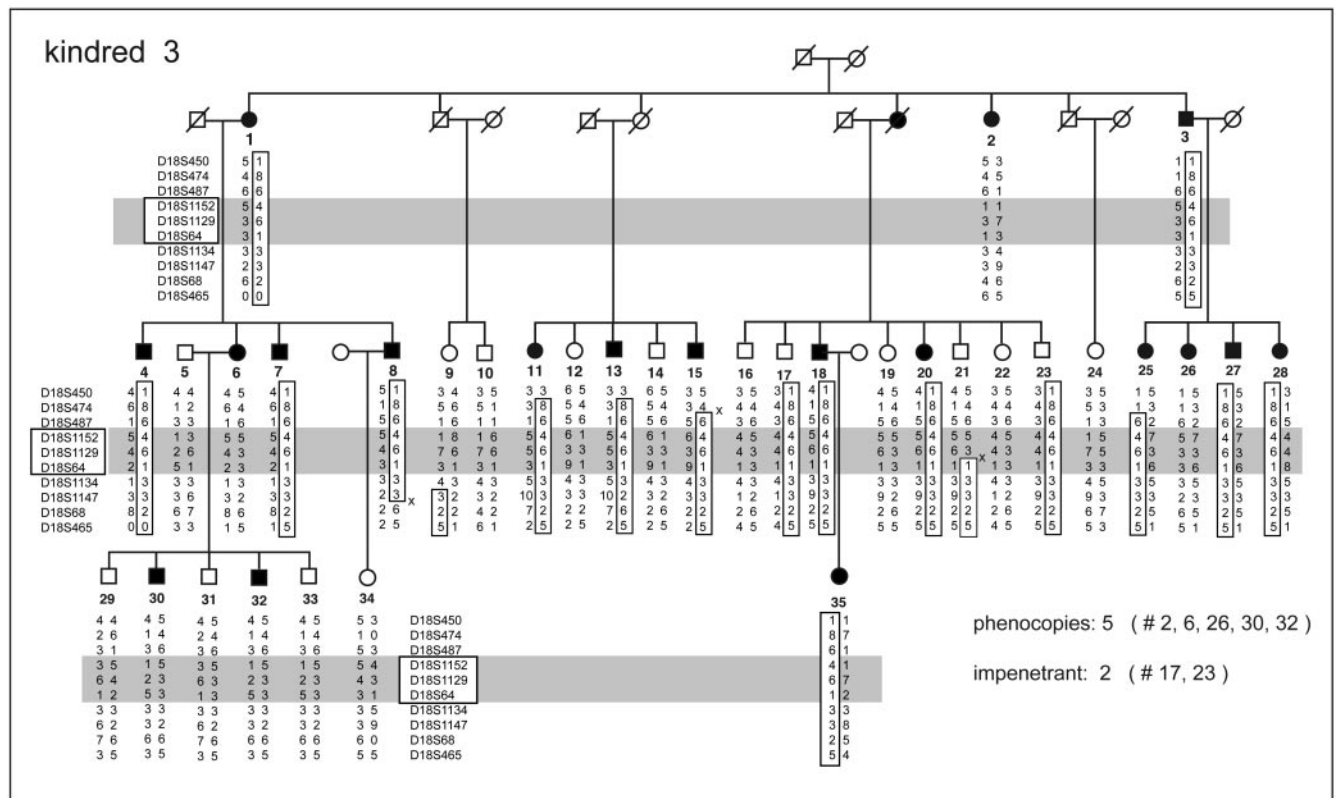

**FIGURE 7.** Haplotype of kindred 3. Haplotypes are displayed as in Figures 5 and 6. Individual 21 showed nonpenetrance at *D18S64*, but was not counted as an obligatory case of impenetrance. Note that the offspring of phenocopy 6 included two more phenocopies, and the 29 to 33 sibship showed no evidence of association between 18q21 and FCD.

**TABLE 2.** Number of Phenocopies and Examples of Nonpenetrance, Relative to the Numbers of Wild-Type and Mutant Haplotypes at the Disease Locus

	PC	nH	NP	mutH	Total H
Kin 1	3	8	1	16	24
Kin 2	0	9	1	9	18
Kin 3	5	19	2	16	35
Total	8	36	4	41	77

PC, phenocopies (FCD affected with normal haplotypes); nH, number of individuals with normal haplotypes; NP, nonpenetrant (unaffected with mutant haplotype); mutH, number carrying the mutant haplotype; total H, total number (nH+mutH).

it remains unknown whether *FCD2* alleles found in the general, unselected FCD patient population have the same degree of penetrance.

Another feature of these families is the overall high phenocopy rate of 22%, which is approximately five times higher than that observed in the general population over 40. This high phenocopy rate could be the result of other genetic factors segregating independently in these families, or an unknown environmental component. The phenocopy rate seems to be higher for kindreds 1 and 3, and so we cannot rule out variability within this study group. Because kindreds 1, 2, and 3 were selected for genetic analysis on the basis of their striking concentration of disease cases, we may have selected for the presence of those FCD-causing mutations that happen to exhibit high penetrance. The selection for familial clustering might also have independently enriched for families with an unusually high phenocopy rate. Thus, the observed penetrance and phenocopy rates in these families should be viewed with great caution, as the estimates are subject to ascertainment bias.

Although both penetrance and phenocopy rates may be higher than in the general population, it is important to realize that the pathology and late age of onset in these families is indistinguishable from the common clinical form of FCD. These three kindreds were recruited in a single clinic from a total set of 62 families. On this basis, we might expect that at least 5% of familial FCD involves the 18q21 locus. Further studies of many smaller families, and identification of the underlying gene mutation, will be necessary to determine how widely the 18q21 locus contributes to familial and sporadic FCD.

Finally, the disease-associated haplotype of kindred 1 (Fig. 8) defines a 7-Mb genomic interval from *D18S487* to *D18S1134* as the most likely site of mutations underlying *FCD2*. Because of the incomplete penetrance observed in these families, the boundaries of this interval cannot be defined

**TABLE 3.** Comparison of 18q21 Locus Disease Haplotypes between Kindreds

Position (Mb)	Marker	Kin 1 Allele (bp)	Kin 2 Allele		Kin 3 Allele	
			Length (bp)	Length (bp)	Length (bp)	Length (bp)
50.0	<i>D18S487</i>	132	130	124		
52.9	<i>D18S1152</i>	270	270	272		
54.7	<i>D18S1129</i>	248	254	242		
55.6	<i>D18S64</i>	323	323	327		
56.9	<i>D18S1134</i>	218	218	218		

Columns contain marker position in megabases from the p-end, marker name, and amplicon lengths of the disease-associated allele for each kindred, in base pairs.

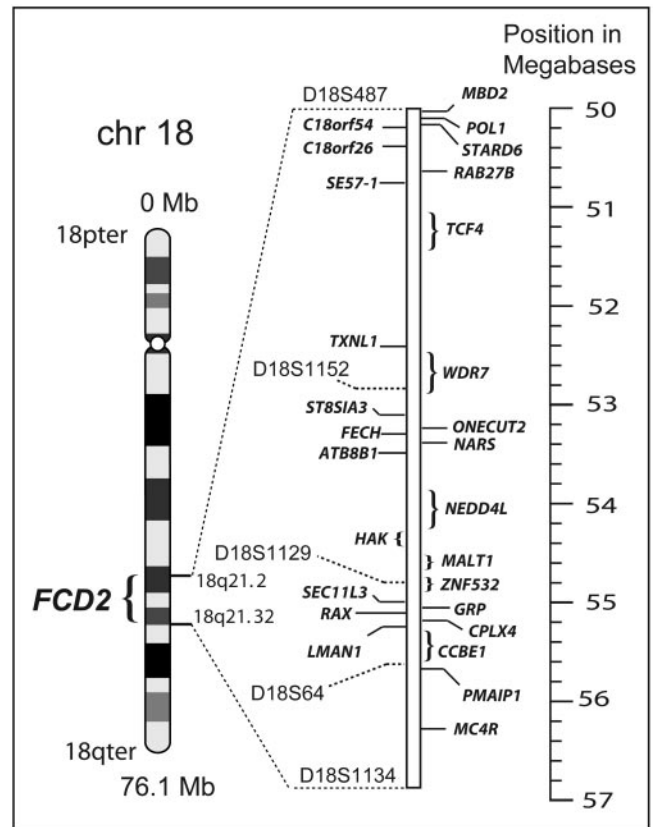

**FIGURE 8.** Gene interval of the chromosome 18 *FCD2* locus based on haplotypes of kindred 1 (Fig. 5). Gene nomenclature and nucleotide positions relative to the p telomere are based on the current map (May 2004 human genome assembly, University of California, Santa Cruz Genome Browser at <http://genome.ucsc.edu>).

as conclusively as in the case of a fully penetrant trait. Given this, the provisional interval shown herein includes 28 annotated genes that are now under investigation.

**References**

1. Fuchs E. Dystrophia epithelialis corneae. *Graefes Arch Clin Exp Ophthalmol.* 1910;76:478-508.
2. Vogt A. Weitere Ergebnisse der Spaltlampenmikroskopie des vordern Bulbusabschnittes. *Arch Ophthalmol.* 1921;106:63-113.
3. Thompson RW Jr, Price MO, Price FW Jr. Long-term graft survival after penetrating keratoplasty. *Ophthalmology.* 2003;110:1396-1402.
4. Waring GO, Bourne WM, Edelhauser HF, Kenyon KR. The corneal endothelium, normal and pathologic structure and function. *Ophthalmology.* 1982;89:531-590.
5. Bergmanson JP, Sheldon TM, Goosey JD. Fuchs' endothelial dystrophy: a fresh look at an aging disease. *Ophthalmic Physiol Opt.* 1999;19:210-222.
6. Krachmer JH, Purcell JJ Jr, Young CW, Bucher KD. Corneal endothelial dystrophy: a study of 64 families. *Arch Ophthalmol.* 1978; 96:2036-2039.
7. Gottsch JD, Sundin OH, Liu S, et al. Inheritance of a novel *COL8A2* mutation defines a distinct early-onset subtype of Fuchs corneal dystrophy. *Invest Ophthalmol Vis Sci.* 2005;46:1934-1939.
8. Hogan MJ, Wood I, Fine M. Fuchs' endothelial dystrophy of the cornea. *Am J Ophthalmol.* 1974;78:363-383.
9. Waring GO, Bourne WM, Edelhauser HF, Kenyon KR. The corneal endothelium: normal and pathologic structure and function. *Ophthalmology.* 1982;89:531-590.

10. Wilson SE, Bourne WM. Fuchs' dystrophy. *Cornea*. 1988;7:2-18.
11. Tuberville AW, Wood TO, McLaughlin BJ. Cytochrome oxidase activity of Fuchs' endothelial dystrophy. *Curr Eye Res*. 1986;5:939-947.
12. McCartney MD, Wood TO, McLaughlin BJ. Moderate Fuchs' endothelial dystrophy ATPase pump site density. *Invest Ophthalmol Vis Sci*. 1989;30:1560-1564.
13. Cross HE, Maumenee AE, Cantolino SJ. Inheritance of Fuchs' endothelial dystrophy. *Arch Ophthalmol*. 1971;85:268-272.
14. Magovern M, Beauchamp B, McTigue JW, Baumiller RC. Inheritance of Fuchs' combined dystrophy. *Ophthalmology*. 1979;86:1897-1923.
15. Chang S W, Tuli S, Azar D. Corneal dystrophies. In: Traboulsi E, ed. *Genetic Diseases of the Eye a Textbook and Atlas*. New York: Oxford University Press; 1998;chap 13.
16. Biswas S, Munier FL, Yardley J, et al. Missense mutations in COL8A2, the gene encoding the  $\alpha 2$  chain of type VIII collagen, cause two forms of corneal endothelial dystrophy. *Hum Mol Genet*. 2001;10:2415-2423.
17. Klintworth GK. The molecular genetics of the corneal dystrophies: current status. *Front Biosci*. 2003;8:687-713.
18. Gottsch JD, Zhang C, Sundin OH, Bell WR, Stark WJ, Green WR. Fuchs corneal dystrophy: aberrant collagen distribution in an L450W Mutant of the COL8A2 gene. *Invest Ophthalmol Vis Sci*. 2005;46:4504-4511.
19. Marshall GE, Konstas AG, Lee WR. Immunogold fine structural localization of extracellular matrix components in aged human cornea. I: Types IV collagen and laminin. *Graefes Arch Clin Exp Ophthalmol*. 1991;29:157-163.
20. Gottsch JD, Bowers AL, Margulies EH, et al. Serial analysis of gene expression in the corneal endothelium of Fuchs' dystrophy. *Invest Ophthalmol Vis Sci*. 2003;44:594-599.
21. Levy SG, Moss J, Sawda H, Dopping-Hepenstal PJC, McCartney ACE. The composition of wide-spaced collagen in normal and diseased Descemet's membrane. *Curr Eye Res*. 1996;15:45-52.
22. Kobayashi A, Fujiki K, Murakami A, et al. Analysis of COL8A2 gene mutation in Japanese patients with Fuchs' endothelial dystrophy and posterior polymorphous dystrophy. *Jpn J Ophthalmol*. 2004;48:195-198.
23. Sundin OH, Jun AS, Broman KW, et al. Linkage of late-onset Fuchs corneal dystrophy to a novel locus at 13pTel-13q12.13. *Invest Ophthalmol Vis Sci*. 2006;47:140-145.
24. Rubin EM, Tall A. Perspectives for vascular genomics. *Nature*. 2000;407:265-269.
25. Merikangas KR, Risch N. Genomic priorities and public health. *Science*. 2003;302:599-601.
26. Rosenblum, P, Stark, WJ, Maumenee IH, Hirst LW, Maumenee AE. Hereditary Fuchs' dystrophy. *Am J Ophthalmol*. 1980;90:455-462.
27. Chiou AG, Kaufman SC, Beuerman RW, Ohta T, Soliman H, Kaufman HE. Confocal microscopy in cornea guttata and Fuchs' endothelial dystrophy. *Br J Ophthalmol*. 1999;83:185-189.
28. Broman KW, Murray JC, Sheffield VC, White RL, Weber JL. Comprehensive human genetic maps: Individual and sex-specific variation in recombination. *Am Human Genet*. 1998;63:861-869.
29. Broman KW, Weber JL. Estimation of pairwise relationships in the presence of genotyping errors. *Am J Hum Genet*. 1998;63:1563-1564.
30. O'Connell JR, Weeks DE. PedCheck: a program for identification of genotype incompatibilities in linkage analysis. *Am J Hum Genet*. 1998;6:259-266.
31. Terwilliger JD, Ott J. *Handbook of Human Genetic Linkage*. Baltimore: Johns Hopkins University Press; 1994.
32. Sobel E, Lange K. Descent graphs in pedigree analysis: applications to haplotyping, location scores, and marker sharing statistics. *Am J Hum Genet*. 1996;58:1323-1337.
33. Sham P. *Statistics in Human Genetics*. Arnold: London; 1998;95-97.